

TWINFLEX 20

FLEXIBLE RUBBER JOINT

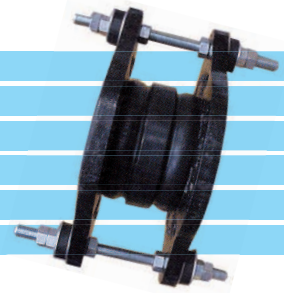

FEATURES

- **High Pressure Application** : Twinflex20 is used in pressurized piping systems where noise and vibration isolation and expansion compensation are necessary. Since the rubber reinforcement with strong chemical fiber is shaped through newly developed technology, the normal working pressure range is (-0.08Mpa) ~ 300 PSI (-600mmHg~20kgf/cm²) and bursting pressure is more than 5.39Mpa (55kgf/cm²). Twinflex20 flexible joint is especially suitable for high-pressure application.
- **Excellent Tightness** : Since the rubber face which is fastened to the metal flange is shaped by a new process, it has excellent water and air tightness.
- **Control Unit Integrated Flange** : The standard design of Twinflex20 comes with Control-Unit-Integrated FCD400 flanges. This is a cheaper solution for applications requiring control units than the traditional Back Plate type. In case of rigidly anchored piping systems where control units may not be needed, ordinary flanges are also available upon request.
- **Outstanding Vibration and Noise Absorption** : Twin sphere structure significantly reduces vibration and noise transmission from operating equipment to the piping system because the joints acts as a damperer which absorbs the greatest percentage of vibration and noise.
- **Other Advantages** :
 - The packing and gasket are not required.
 - Applicable both as expansion joint and flexible joint, and also applicable for both purposes concurrently.
 - Low electrical conductivity.
 - Mass production makes comparatively low price possible.

APPLICATIONS

- Chilled water air conditioning equipment, water pumps, sewerage and sanitary piping systems, etc.
- Pressure piping systems for water and warm water used in building equipment and general industrial plants, etc.
- Pump line and turbine lines used for power generation plants, industrial machinery and universal pump blowers, etc.

STRUCTURE

No.	Parts	Materials
1	Integrated Flanges	Cast Iron (FCD400)
2	Reinforcing Ring	Carbon Steel (SWRH)
3	Inside Rubber	Synthetic Rubber
4	Outside Rubber	Synthetic Rubber
5	Reinforcing Fiber	Synthetic Fiber
6	Bolts, Nuts, Washer	Mild Steel (SS400)
7	Bushing	Hard Rubber

- Ordinary flange material can be provided to FCD400, mild steel or SUS304.
 - Available flange standards are JIS, ANSI, BS, DIN and others (drillings).
 - Synthetic rubber is EPDM which is the standard material. (Other kinds of rubber material are optional.)
 - Structure of vacuum ring will be added for alternative to withstand full vacuum.

● Dimension and Allowable Movement

Size (mm)	Dimension (mm)			Allowable Movement (mm)				Installation Allowance (mm)			
	L	ØD2	ØD1	T.M.	A.E.	A.C.	A.M.(°)	T.M.	A.E.	A.C.	A.M.(°)
150	175	212	150	20	20	30	20	8	6	6	5
200	200	264	200	20	20	30	15	8	6	6	5
250	200	324	250	20	20	30	10	8	6	6	3
300	200	372	300	20	20	30	10	8	6	6	3

T.M. = Transverse Movement A.E. = Axial Elongation A.C. = Axial Compression A.M. = Angular Movement

● Operating Condition

Working Pressure : 20 kgf/cm² (300 PSI) at normal temperature
 Negative Pressure : -600 mmHg.
 Working Temperature : -10°C ~ +80°C
 Applicable Fluid : Water, Sea Water, Warm Water, Weak Acid,

● Control Units

Control units are not required for piping systems with rigidly anchored supports on both sides of a flexible joint. The rigidly anchored supports must be capable of withstanding pressure thrusts generated by the internal pressure or wide temperature fluctuations.

Control units are always recommended to be used with Twinflex20 for unanchored piping systems, non-rigidly anchored system, and piping systems connected to spring mounted equipment. Furthermore, control units are always recommended to prevent movements beyond Twinflex20's limited specification.

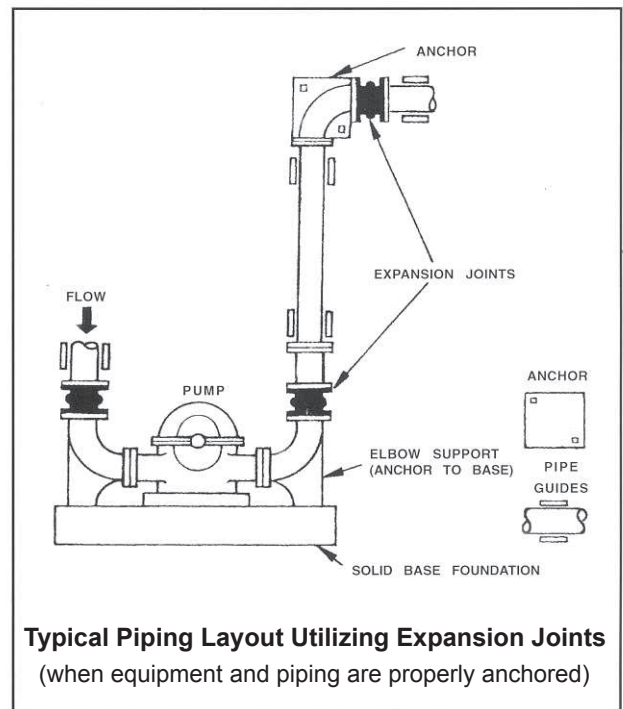

● Notes

1. Information in the above table is for single displacement only. In case of complex displacement, follow the below expression.

$$C.EL(C) = A.EL(C) \times \left\{ 1 - \left(\frac{A.T.M. - T.M.}{A.T.M.} \times \frac{A.A.M. - A.M.}{A.A.M.} \right) \right\}$$

C.EL(C) = Correct Elongation (Compression)

T.M. = Transverse Movement

A.EL(C) = Allowable Elongation (Compression)

A.A.M. = Allowable Angular Movement

A.T.M. = Allowable Transverse Movement

A.M. = Angular Movement

- Install the joint within the range of installing allowance. Do not install joints at full limits of all allowable movement simultaneously.
- In order to avoid elongation of the joint by the reaction force resulted from water pressure, fix pipes before and behind the joint. If the fixing of the pipes is not sufficient, install the tie rods (control unit) to the joints for protection.
- Fix the bolts and nuts on the counter flange side (external side).
- When installing the joint, check for cracks on rubber body surface, especially after a long period of storage.
- Keep away from heating source when install. Cover the joint with protection sheet to free from any harm of spark resulted from welding, pre-arcing and grinding near the spot of joint installation.
- If oils, fats, organic solvent (e.g. thinner, toluene), acid or alkali are adhered, wipe them off quickly.
- Avoid direct exposure of sunlight in case of outdoor piping to prevent aging and deterioration of rubber.

TOZEN (THAILAND) CO., LTD.

3388/62 18TH FLOOR, SIRINRAT BLDG.,
 RAMA IV RD., BANGKOK 10110 THAILAND
 TEL : (66) 0-2367-5721-8
 FAX : (66) 0-2367-5729, 0-2367-5066
 URL : www.tozen.co.th

TOZEN CORPORATION.

8-4, ASAHY YOSHIKAWA
 SAITAMA 342-008 JAPAN
 TEL : 048-993-1030
 FAX : 048-993-1038