

POS

Technical submission

R 2.0

Type of Product XT series complete Terminal valve assembly for fixed and adjustable flushing by-pass for axial PICV.



This technical submittal contains information that to the best of our knowledge correct at the time of publishing. Fratelli Pettinaroli reserves the right to change the specification of our assemblies at any time. Errors and omissions excepted.

TABLE OF CONTENTS

Technical submission	1
Design and selection	1
Introduction	1
Function	1
Configurations	2
<i>Fixed centre to centre distance.</i>	2
Selection	3
<i>Variable centre to centre distance.</i>	5
Selection	5
Flow rate control.....	7
Temperature control.....	7
<i>Authority</i>	7
Labelling and identification	8
Testing	8
Data	8
Drawings	9
Performance charts	14
Dynamic Flow Data	14
Control valve characteristic	18
Installation and operating instructions	19
Installation.....	19
<i>Media quality</i>	19
Flushing and isolation	19
<i>Fixed centre to centre distance.</i>	20
Mains flush	20
Flush to drain	20
Filling and purging	21
Normal operation	21
<i>Variable centre to centre distance.</i>	22
Mains flush	22
Flush to drain	22
Filling and purging	23
Normal operation	23
Setting and commissioning.....	24
<i>Pre-setting</i>	24
<i>Setting to a flow rate</i>	24
Flow and differential pressure measurements.....	25
<i>Differential pressure across the terminal unit</i>	25
<i>Differential pressure across the EVOPICV valve</i>	25
<i>To measure the flow rate passing through the terminal unit</i>	25
<i>Maintenance</i>	25
<i>Replacement of the terminal unit</i>	25
Replacement of the diaphragm of EVOPICV 91 valve - 091SET maintenance kit.....	26
Replacement of the diaphragm of EVOPICV 93 valve	28
<i>Replacement parts</i>	28
Individual components	29
EVOPICV	29
Filterball strainer	31
Coil connection tee.....	32
Blow down valve	32
Flushing by-pass	33
Venturi flow measurement (optional).....	35
<i>Flow measurement chart</i>	36
<i>Replacement of venturi</i>	36
Union connections.....	37

Insulating case (optional)	37
Flexible hoses (optional)	38
Actuation	39
Actuator selection	39
Actuator fitting	39
<i>Motorised actuators</i>	39
<i>Thermic actuators – EVOPICV</i>	40
<i>Removing black protection handle</i>	40
Actuator details	41
<i>0-10V Proportional (configurable)</i>	41
<i>24v 3 Point motorised</i>	41
<i>24V or 230V Thermic On/Off</i>	42
<i>0-10V Proportional thermic</i>	42
Note	43

DESIGN AND SELECTION

Introduction

The XT range of Terminal valve assemblies has been designed to include all of the valves and connections for controlling and maintaining terminal units. These functions are included in a PCS kit, that has been designed to be assembled and mounted in the pipe work to the terminal unit by the installer.



Example of fully featured XT801

Function

The XT kit includes an EVOPICV axial pressure independent control valve to maintain design flow rates and provide modulating temperature control, also included in the assembly is isolation valves on both flow and return. The flow valve is typically a combined isolation valve and strainer, Filterball. (Y type filter on demand). The return valve is either incorporated on the fixed by-pass or a separate valve on the adjustable centre flushing by-pass. A flushing by-pass and blow down valve are offered so that the valve set and connected terminal unit may be flushed out of circuit and subsequently forward flushed.

The XT series has been designed to provide maximum flexibility and allow customization in a number of configurations. Varying the components and adjusting the centre to centre distance of the flushing by-pass. In addition, some specific configurations can be further adjusted by the rotation of individual components to best suit the installation.

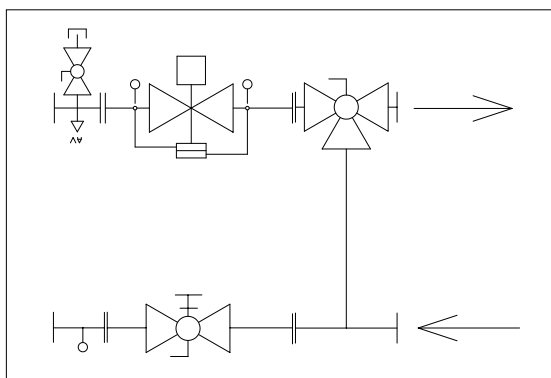

Schematic Representation XT801

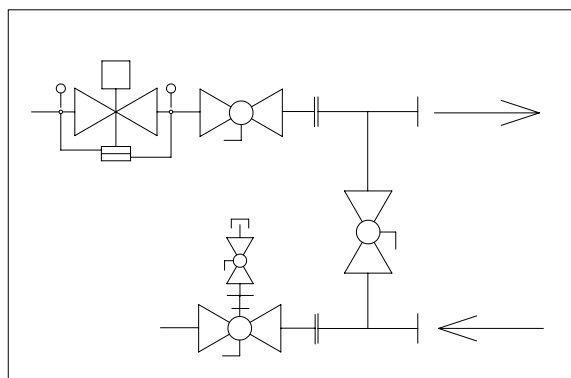

Schematic Representation XT1300

The valve assembly is offered with fixed and adjustable centres, to suit most of the Consultants terminal design. A wide range of end connections are available.

- Fixed centre to centre by-pass assemblies are the XT600, XT700 and XT800 range
- Adjustable centre to centre by-pass assemblies are the XT1300 range to XT3000 range

Configurations

Fixed centre to centre distance.

This configuration includes the following products which can be partially modified according to customer needs. They are supplied with 40 mm, 70 mm or 80 mm centre to centre distance by-pass (main riser side) and with or without tees with drain, air vent and additional pressure gauge.



XT600 and XT601 series



XT700 and XT701 series



XT800 and XT801 series



XT850 and XT851 series

Selection

The selection of a fixed by-pass assembly is made on piping centres, pressure loss and flow rates. A number of fixed centre assemblies and their configurations have already been detailed. Several more variations including different sizes of EVOPICV, the inclusion of draining and venting and the type/size of end connections have been included in the design selection table below.

To ensure that there is sufficient differential pressure through the index terminal unit and the Pressure Independent Control valve the minimum assembly differential pressure has been determined and also included in the design selection table below.

Base Code	Centre to centre	Connections available	Flow rates range		PICV Min ΔP	Assy' Min ΔP	Kv by-pass	Filtering Capacity	Drain and air vent	Additional pressure gauge	
			Min [l/h]	Max [l/h]							[kPa]
	[mm]							μm			
XT600	40 In 60 Out	½" F x ½" F	15	150	20	20	3	700	No	No	
			60	600	25	35					
			78	780	35	35					
XT601	40 In 60 Out	½" F union end x ½" F ¾" F union end x ½" F	15	150	20	20	3	700	Yes	Yes	
			60	600	25	35					
			78	780	35	35					
XT700	70	½" F Union end x ½" F	15	150	20	25	2.6	700	No	No	
			60	600	25	35					
			78	780	35	35					
		¾" F union end x ¾" F		100	1000	30					45
				450	1500	35					50
XT701	70	½" F double union end	15	150	20	25	2.6	700	Yes	Yes	
			60	600	25	35					
			78	780	35	35					
		¾" F double union end		100	1000	30					45
				450	1500	35					50
XT800	80	½" F union end x ½" F ¾" F union end x ½" F	15	150	20	25	8	700	No	No	
			60	600	25	35					
			78	780	35	35					
		¾" F x ¾" F union end ¾" F x 1" F union end 1" F double union end		100	1000	30					45
				450	1500	35					50
XT801	80	½" F double union end ¾" F double union end 1" F double union end	15	150	20	25	8	700	Yes	Yes	
			60	600	25	35					
			78	780	35	35					
		¾" F double union end 1" F double union end		100	1000	30					45
				450	1500	35					50
XT850	80	1" F double union end	220	2200	25	40	8	700	No	No	
			270	2700	30	45					
			300	3000	35	60					
XT851	80	1" F double union end	220	2200	25	40	8	700	Yes	Yes	
			270	2700	30	45					
			300	3000	35	60					

NOTE: Male Union End available upon request

The flow rate range indicates the maximum and minimum range of design flow rates that the XT can be used to control and measure. The fixed centre XT by-pass selection can be made on min and max flow range depending on the PICV used. A flow measuring Venturi can be included in the assembly to verify flow. However only differential pressure can be measured across the PICV and if appropriate test points fitted across the terminal device. Sizing PICV valves at their maximum duty should be avoided. A safety margin for possible flow rate changes and water balancing should always be a consideration.

PICV Min ΔP is the minimum differential pressure required to provide pressure independent flow control for each PICV selection, where the PICV is 100% open. This value reduces as the valve is regulated.

Assembly Min ΔP is the pressure loss through the XT with the PICV valve set to provide the maximum extended range flow rate and allowing for the minimum differential pressure requirement of the PICV to be met. This value can be used during pump selection.

The inclusion of accessories such as

- Tees to allow for the inclusion of drains, air vents, unions
- Tees with caps to allow for the inclusion of pressure gauge
- Filterball with drain (an alternative to Tee with drain)
- Venturi flow measurement (appropriately sized to achieved design signal)
- Insulation case for heating and chilled water
- Flexible hose pipes for terminal connections



- Standard configuration
- Optional configuration

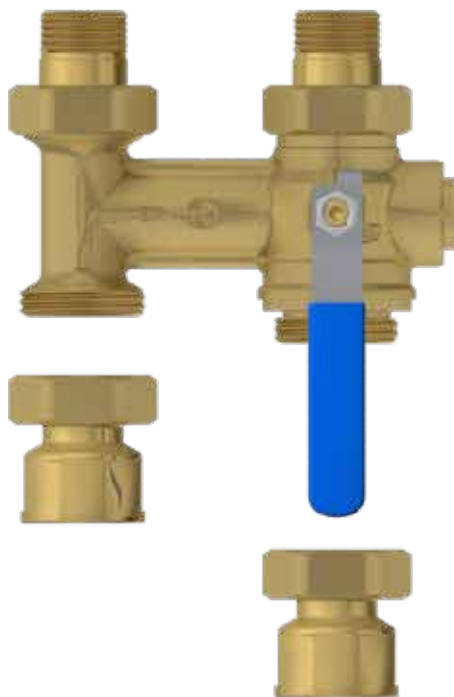
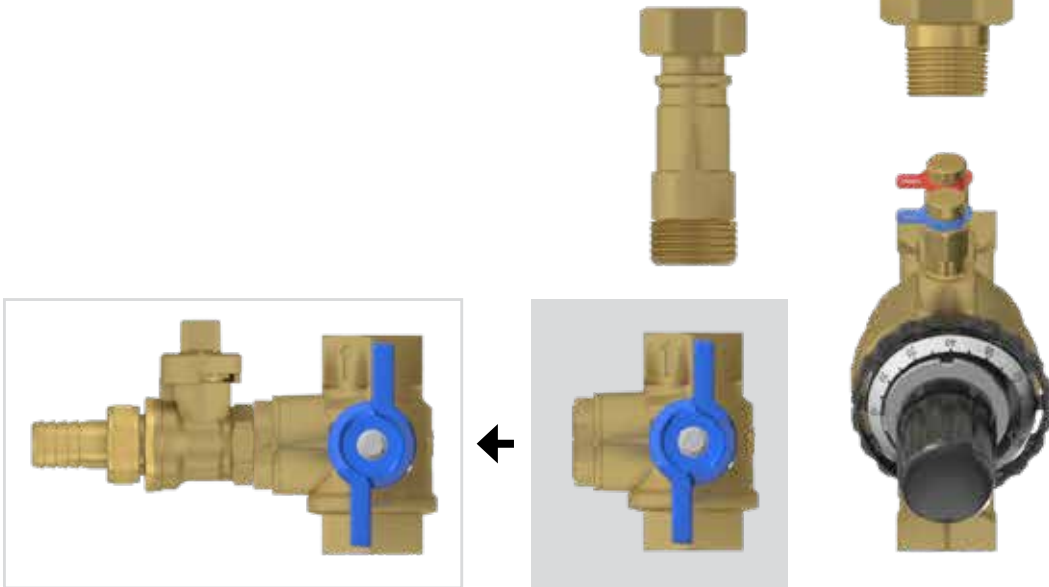
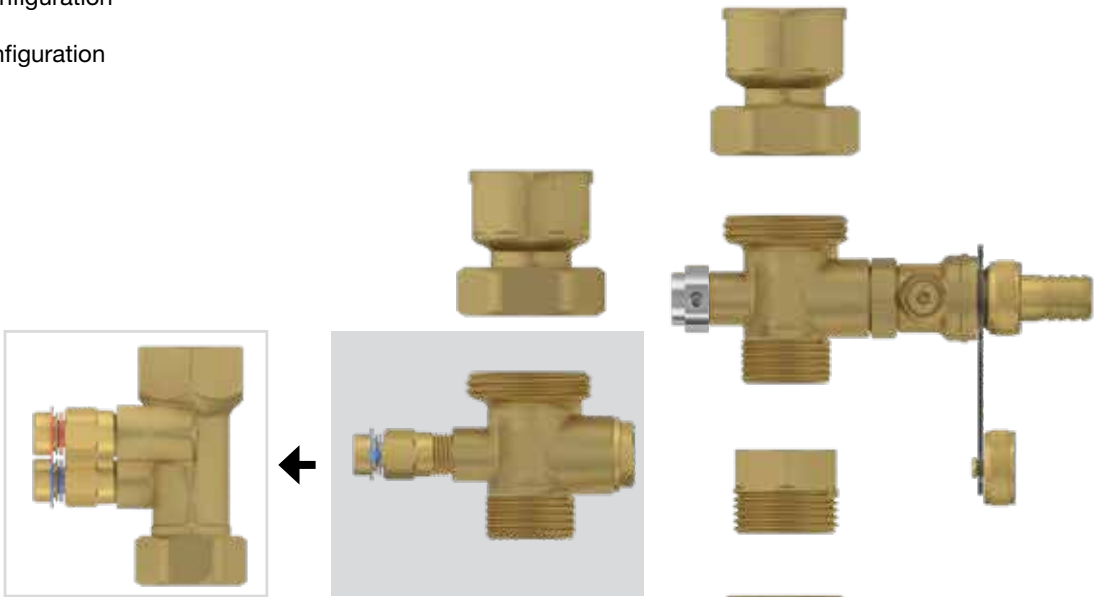

Variable centre to centre distance.

An adjustable centre to centre by-pass has been designed by Pettinaroli to meet the needs of customers who prefer to customize their assemblies to suit Consultant requirements and on site conditions. It is supplied with a variable centre to centre distance by-pass, from 130 mm to 300 mm, which has to be specify by the customer. A Pettinaroli typical assembly and configurations includes different sizes of EVOPICV, the inclusion of a Filterball valve in the flow, an isolation valve in the return and flushing by-pass. The inclusion of drains, air vents, Y type strainers and Venturi flow measurement are available options.

The valves included in the customized XT assemble can also be orientated as required. Terminal unit connections mounted either in a parallel to the flow or at 45 degrees orientation are best served by the horizontal configuration. Terminal unit connections mounted vertically will typical required left hand and right hand variable centre distance XT units.

Two Pettinaroli XT assemblies are shown below.



Pictures of the XT variable centre to centre distance

Selection

Selection is performed on centre to centre distance of the by-pass and on design flow rate. There are several variations of the EVOPICV and additional components; the selection table shows the valve and the connection selections based on flow rate and by-pass distance.

To ensure that there is sufficient differential pressure through the index terminal unit and the Pressure Independent Control valve the minimum assembly differential pressure has been determined and also included in the design selection table below.

Base Code	Centre to centre	Connections available	Flow rates range		PICV	Assy'	Kv by-pass	Filtering Capacity
			Min [l/h]	Max [l/h]	Min ΔP [kPa]	Min ΔP [kPa]		
	[mm]				[kPa]	[kPa]		µm
XT ----	from 130 to 300	½" F x ½" F union end ½" F x ¾" F union end	15	150	20	25	6,5	700
			60	600	25	35		
			78	780	35	35		
		¾" F x ¾" F union end	100	1000	30	45		
			450	1500	35	50		
		¾" F double union end 1" F union end x ¾" F union end ¾" F union end x 1" F union end 1" F double union end	220	2200	25	40		
			270	2700	30	45		
			300	3000	35	45		

The flow rate range indicates the maximum and minimum range of design flow rates that the XT can be used to control and measure. The fixed centre XT by-pass selection can be made on min and max flow range depending on the PICV used. A flow measuring Venturi can be included in the assembly to verify flow. However only differential pressure can be measured across the PICV and if appropriate test points fitted across the terminal device. Sizing PICV valves at their maximum duty should be avoided. A safety margin for possible flow rate changes and water balancing should always be a consideration.

The inclusion of accessories such as

- Tees to allow for the inclusion of drains, air vents, unions
- Tees with caps to allow for the inclusion of pressure gauge
- Filterball with drain (an alternative to Tee with drain)
- Venturi flow measurement (appropriately sized to achieved design signal)
- Insulation case for heating and chilled water
- Flexible hose pipes for terminal connections

- Standard configuration
- Optional configuration

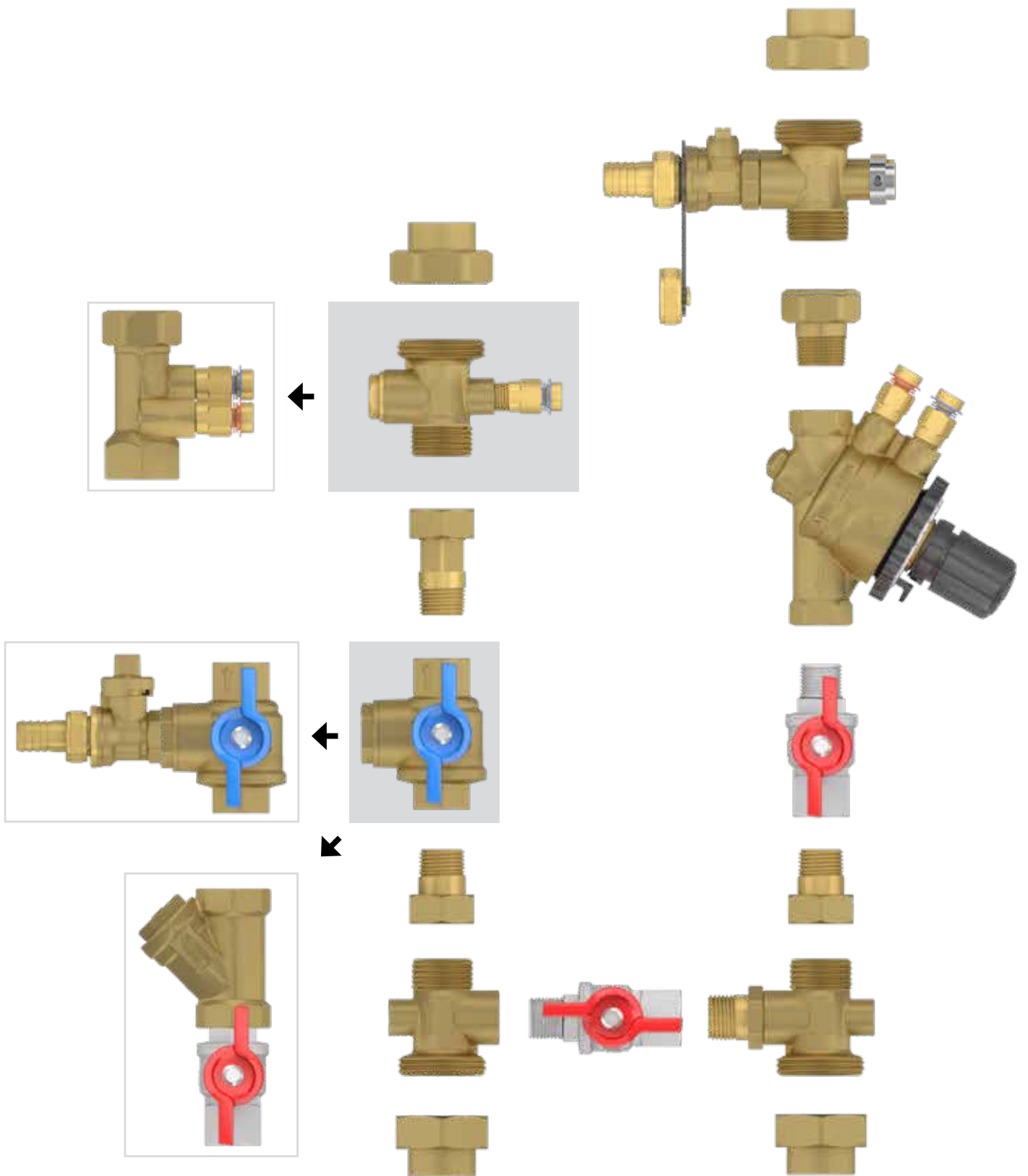

Flow rate control

The internal pressure regulator (shown in red below) maintains a constant differential pressure across the seats (P2 –P3 in the diagram below) in the EVOPICV. As flow rate is proportional to the product of differential pressure and area of passage, holding the differential pressure constant means that flow rate is only determined by the area of passage. The design flow rate is set using the black hand wheel on the EVOPICV valve. Moving this hand wheel reduces the area of passage through the pre- setting seat of the EVOPICV valve.

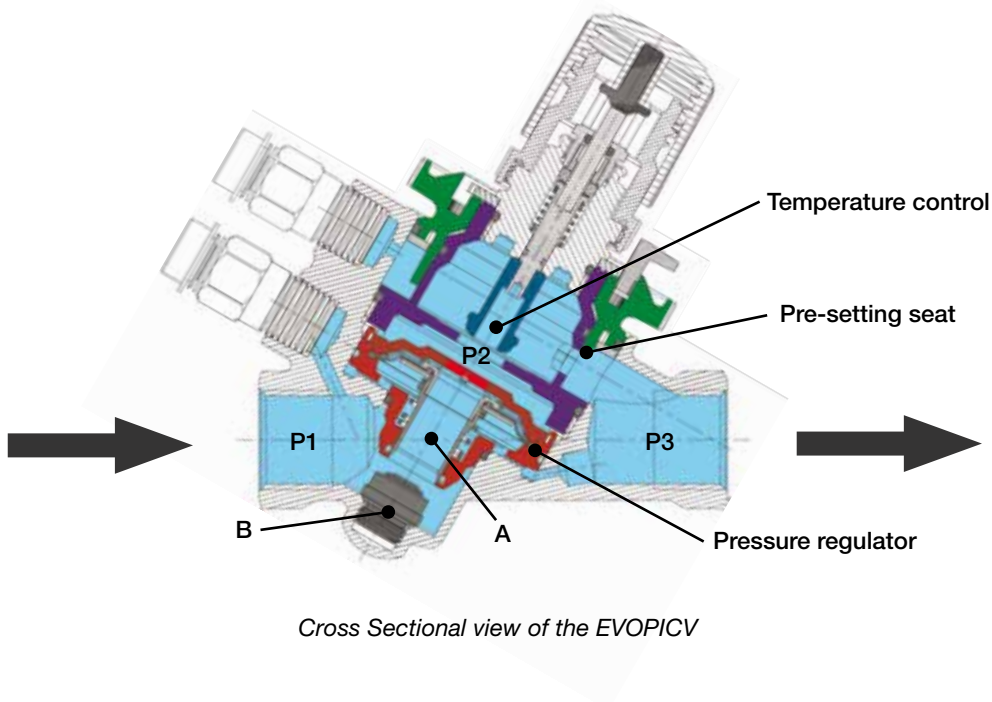

The hand wheel is graduated in percentage of the maximum flow through the valve. Upon receipt of the required design flow rates Fratelli Pettinaroli will return a schedule of valve selections along with the pre-set positions.

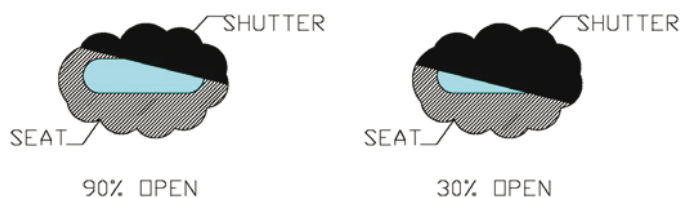

Indication of how the Pre-Setting Seat Operates

Temperature control

The EVOPICV also includes an oblique type globe valve for temperature control purposes. This globe valve is capable of being controlled by a wide range of actuators, including thermoelectric actuators and motorised actuators.

Authority

The authority (n) of a valve can be calculated from the pressure drop across that valve compared with the local system. In this case written as

$$n = \Delta P_v / \Delta P_{sys}$$

In the case of a pressure independent control valve the differential pressure across the control valve is controlled to the same value regardless of whether the valve is fully open, closed or at part load. This means that a pressure independent control valve has an authority of 1.

For more information on designing PICV systems please see Fratelli Pettinaroli' Definitive guide to Pressure Independent Control Valves.

Labelling and identification

The labelling is also intended to make the flow and selection criteria clear when to technician is working on it. Therefore, the size of PICV fitted can be identified by the markings on the setting hand wheel and chrome disk on the head work.

Valve type	Part Code on Hand Wheel	Chrome Disc Marking
91VL	91VL ½" 150 l/h	150 l/h
91L	91L ½" 600 l/h	600 l/h
91H	91H ½" 780 l/h	780 l/h
91L	91L ¾" 1000 l/h	1000 l/h
91H	91H ¾" 1500 l/h	1500 l/h
93L	93L 1" 2200 l/h	2200 l/h
93H	93H 1" 2700 l/h	2700 l/h
93H	93H 1 1/4" 3000 l/h	3000 l/h

Table 1

Testing

Each valve set is leak tested by means of air pressure decay using a fill pressure of 4 bar against with a maximum acceptable leakage of 90 cm³/h.

DATA

Characteristic	
Pressure rating	PN25 (PN16 with flexible hoses)
Flow rate range	15 – 3000 l/h dependent on valve selection
Working temperature range [^]	-10 - +100° C
Working differential pressure range	25 – 600kPa minimum depends on valve and setting
Flow control accuracy (linearity and hysteresis)	±5% till 1 bar DP, ±10% over 1 bar DP at 100% flow
Control valve characteristic	Equal percentage
Control valve leakage rate to IEC 60534-4	Class IV
Available thread types	BSP and NPT (*)
Medium	Water or Water-Glycol 30%

[^] no frost and no steam. Under 0°C, glycol must be added. See temperature limits of flexible hoses and actuators (dedicated technical specifications sheets).

* The XT kits with NPT thread have different code following the example: XT601 (BSP) becomes X601/A (NPT)

DRAWINGS

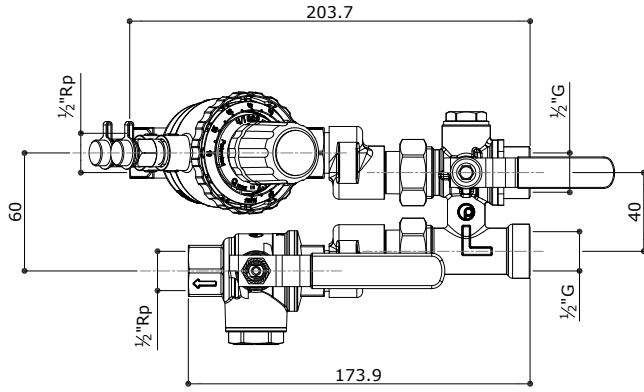

XT600

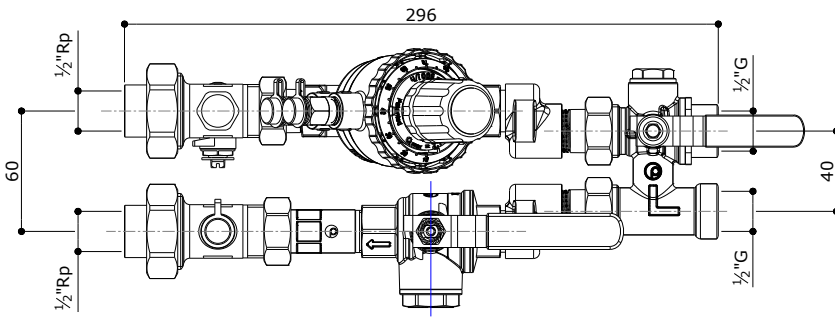
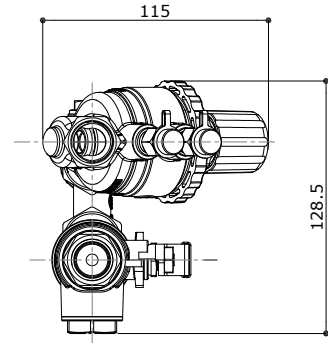

XT601

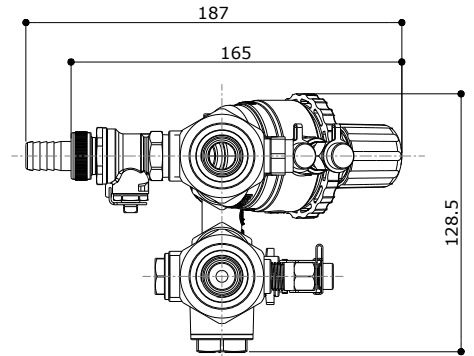

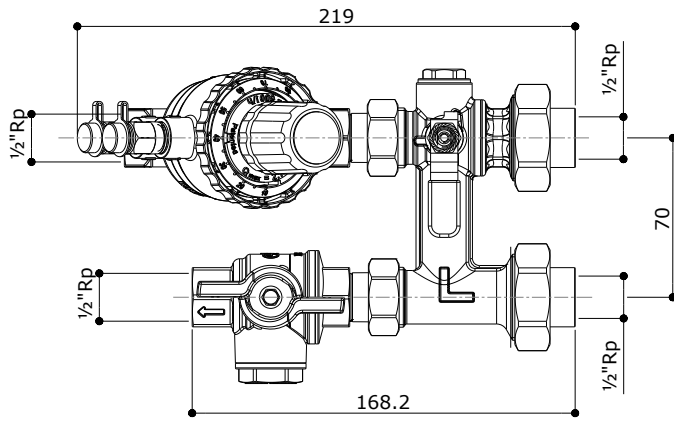

XT700

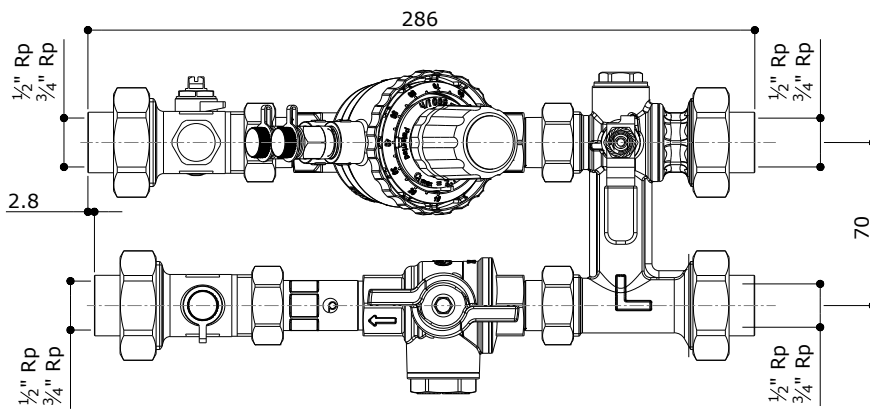
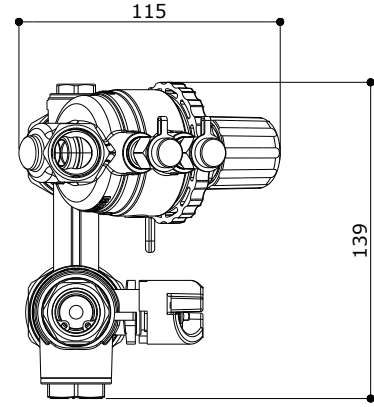

XT701

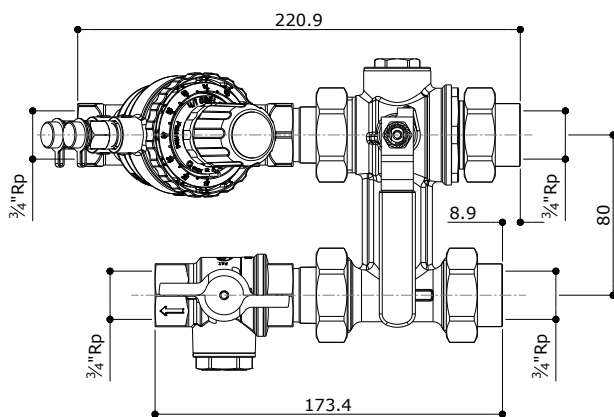
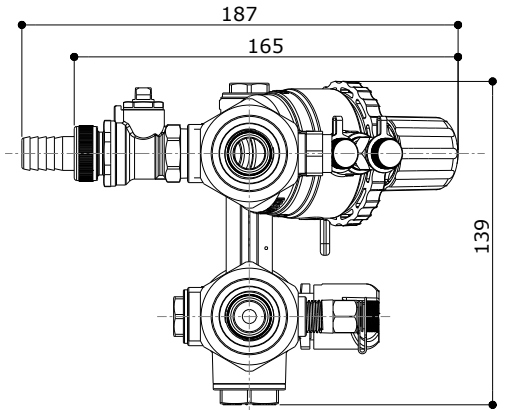

XT800 3/4"

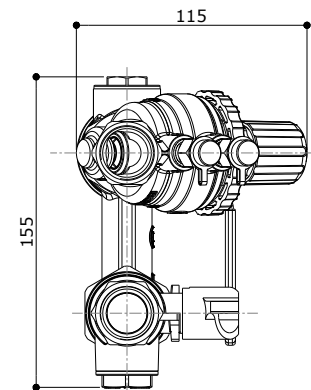

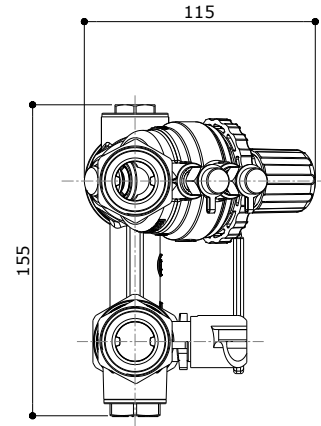
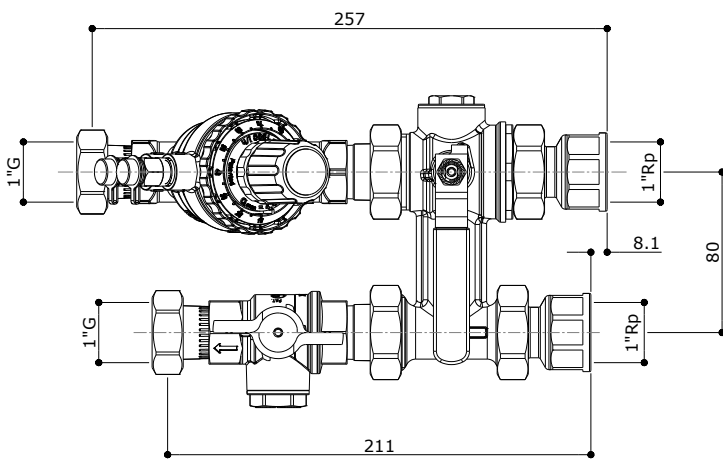

XT800 1"

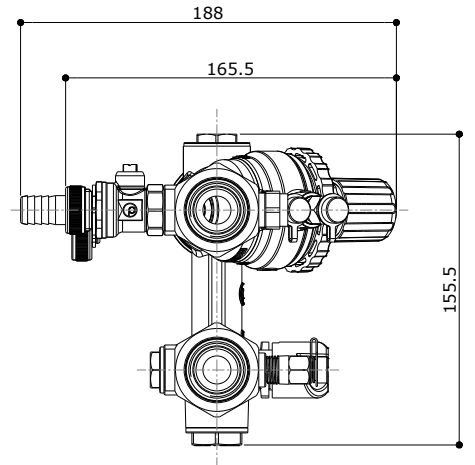
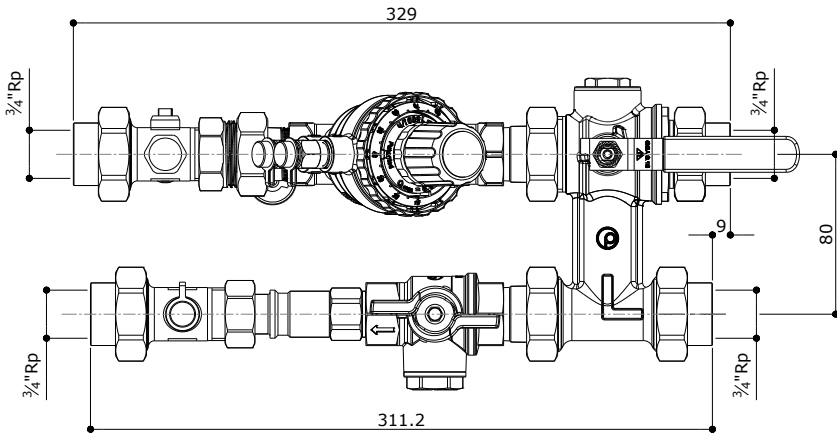

XT801 3/4"

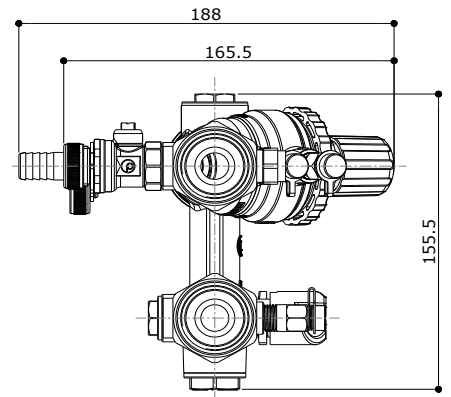
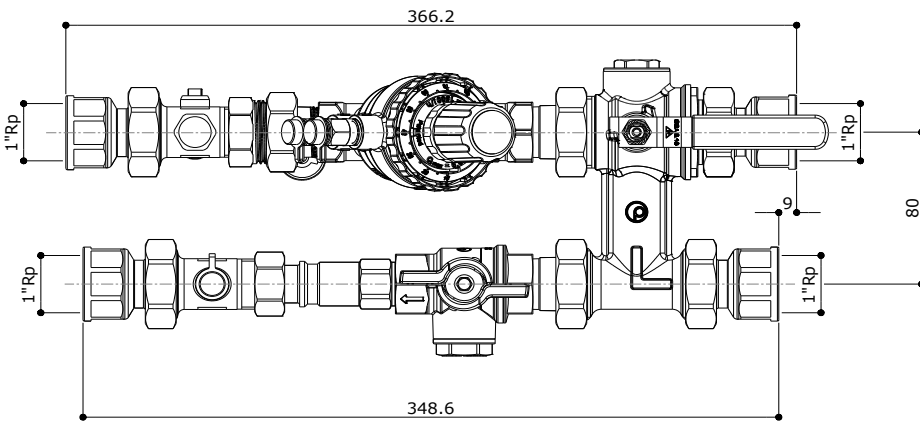

XT801 1"

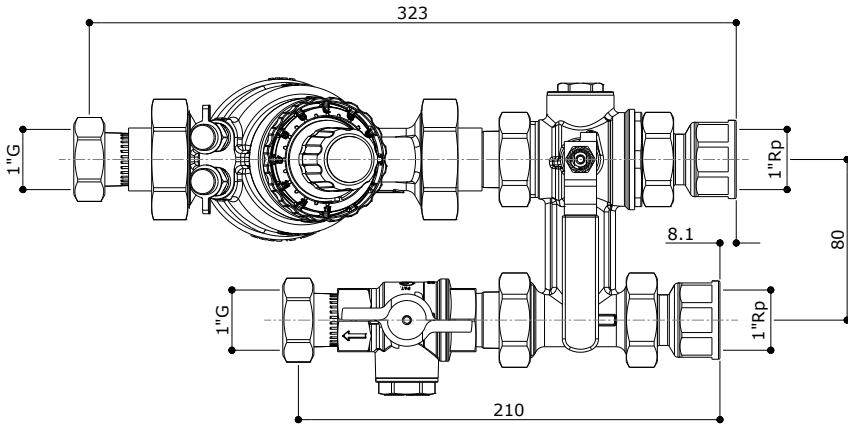

XT850

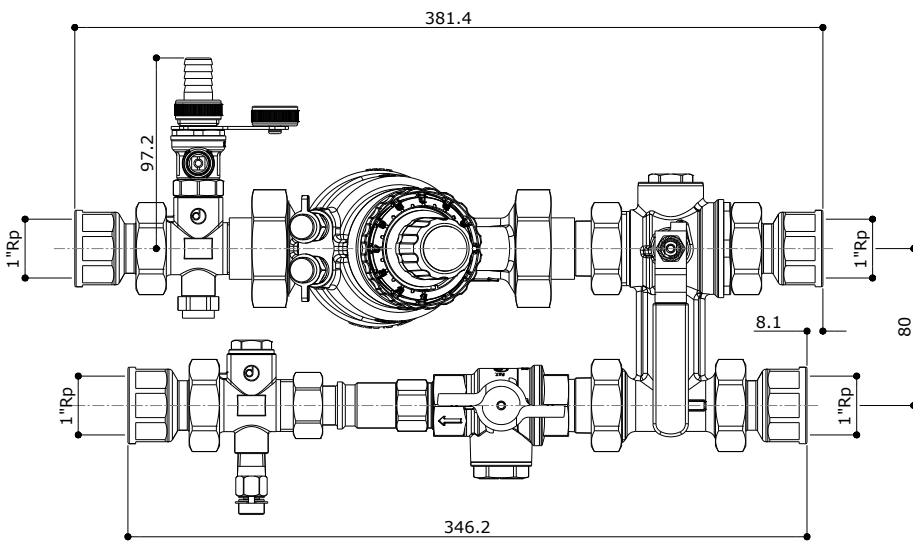
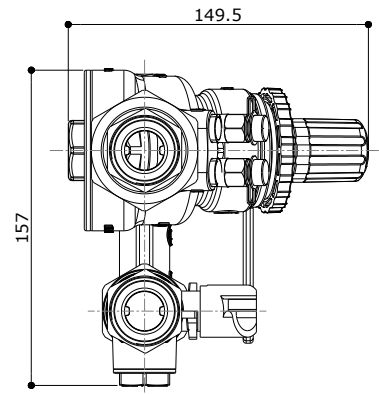

XT851

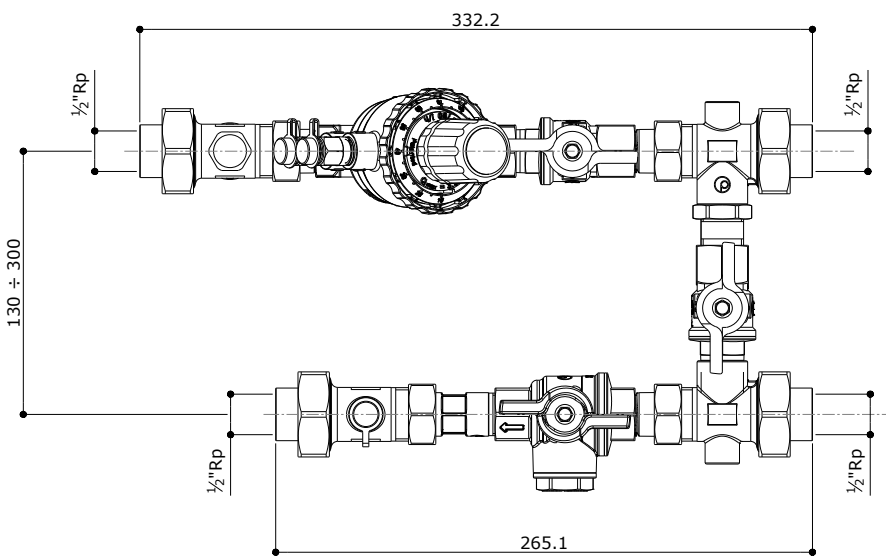
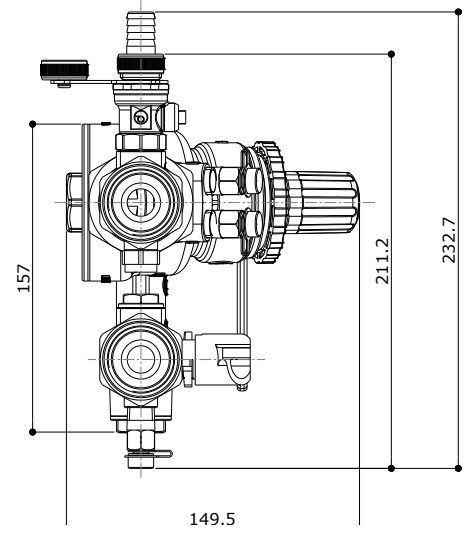

XT variable center to center distance with accessories

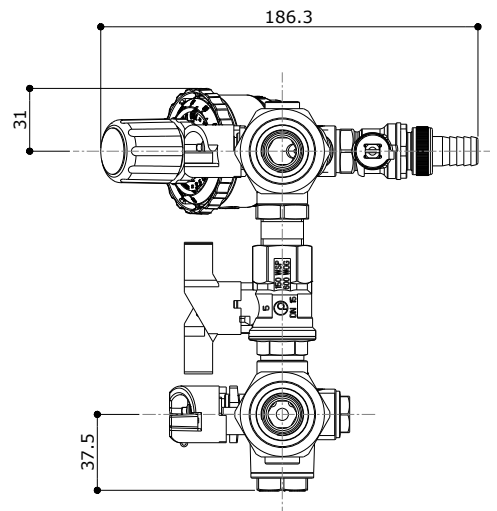

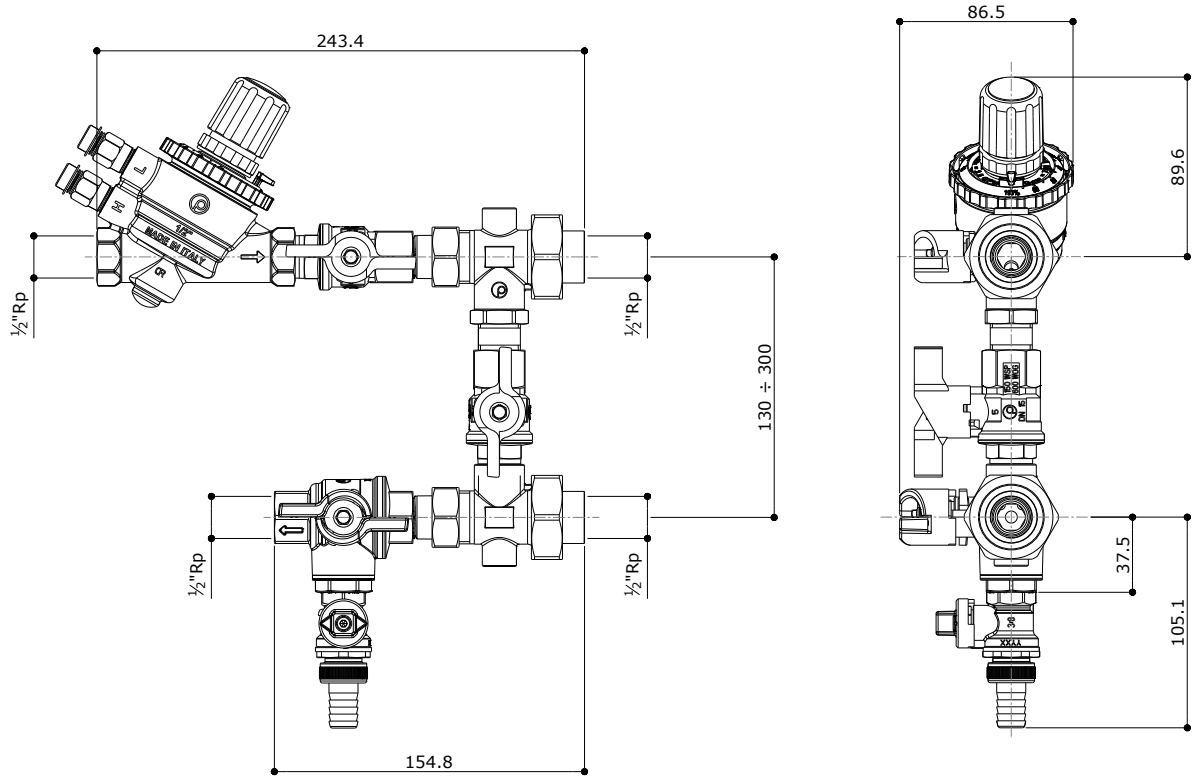

XT variable center to center distance

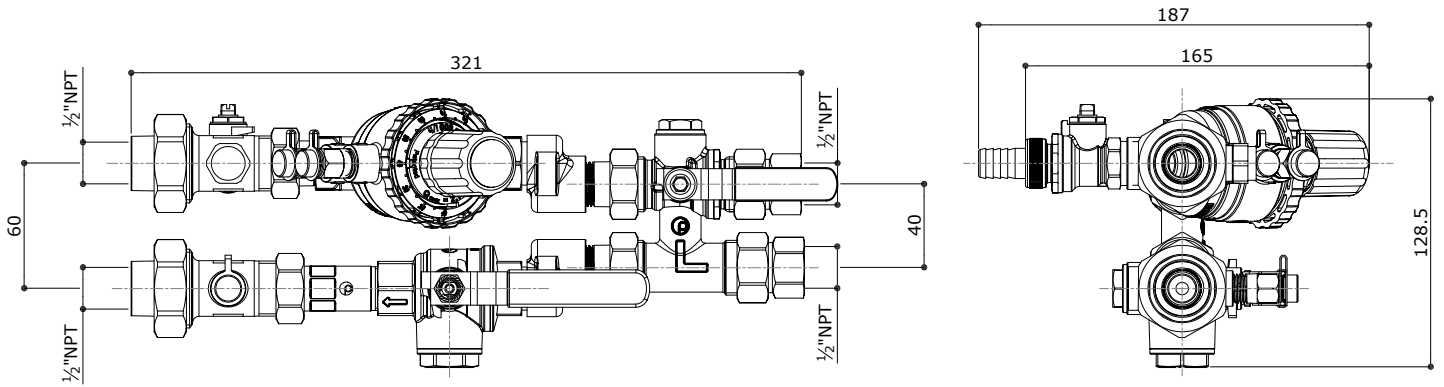

X601/A 40 to 60 mm center to center distance NPT thread

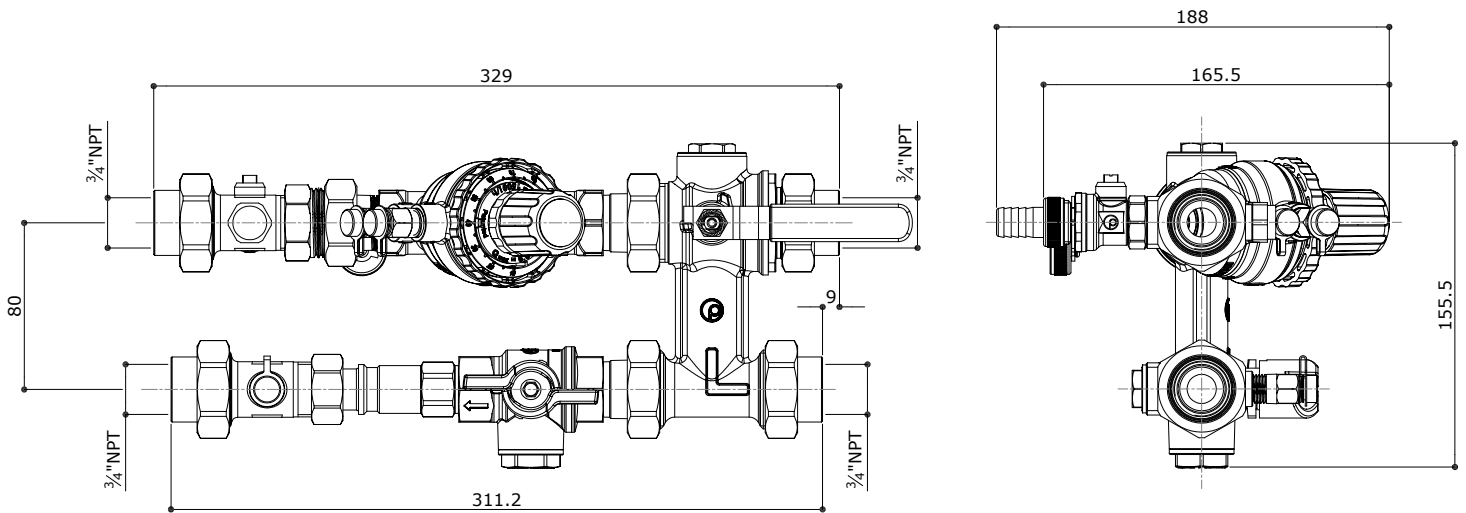

X801/A 80 mm center to center distance NPT thread

PERFORMANCE CHARTS

Dynamic Flow Data

The dynamic flow charts presented below indicate the flow response in l/h for several particular valve settings with varying differential pressure. This allows the performance of the valve to be evaluated and the start-up pressure (the differential at which the valve starts to control the flow rate) to be observed. The charts below show the pressure loss across the entire XT assembly; measurements were taken at the inlet and outlet connection.

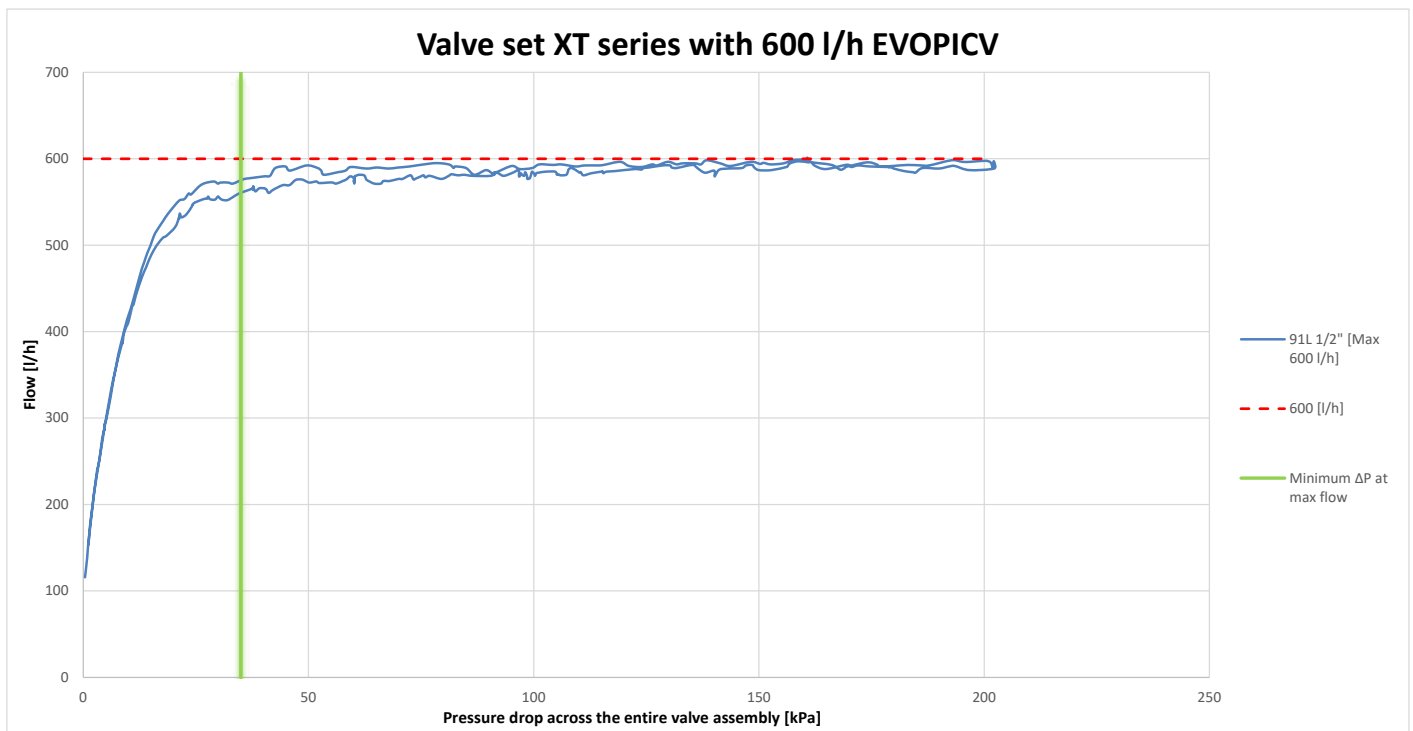
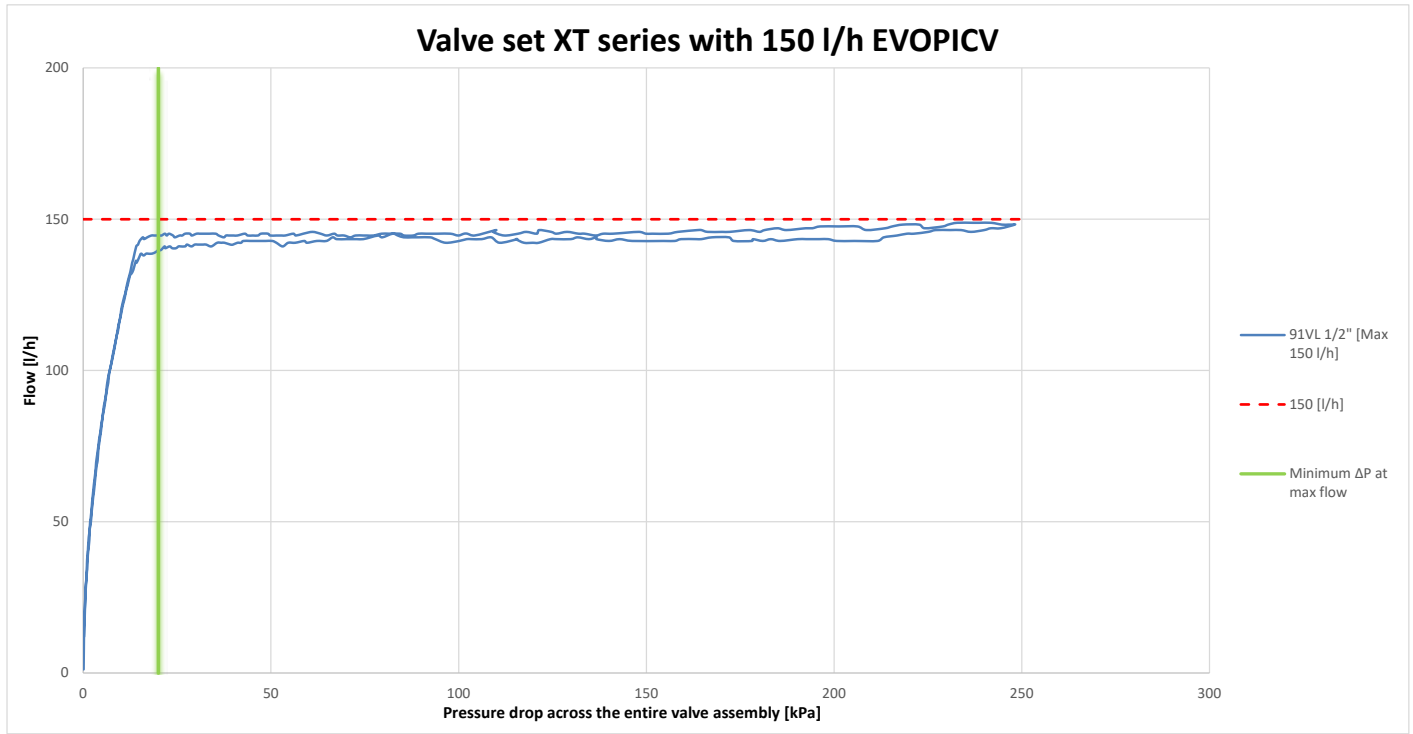

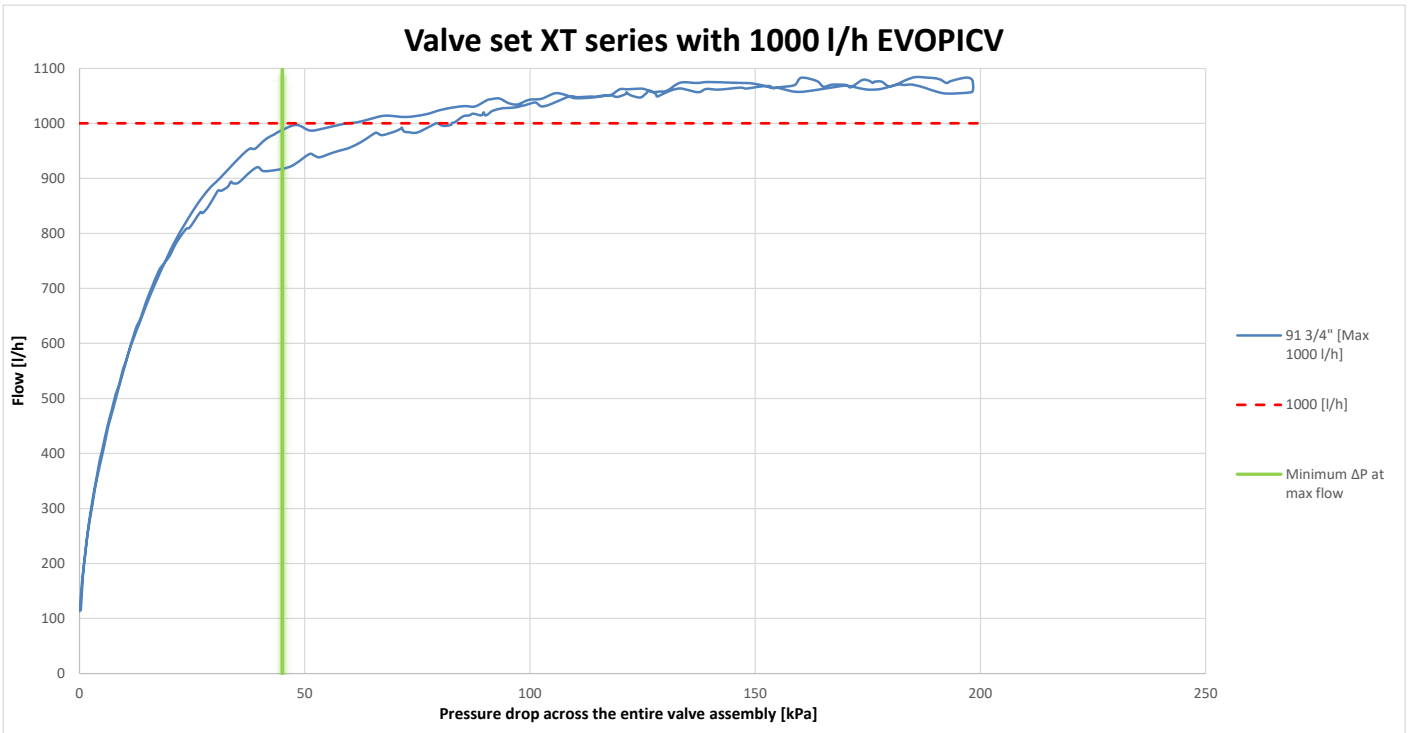
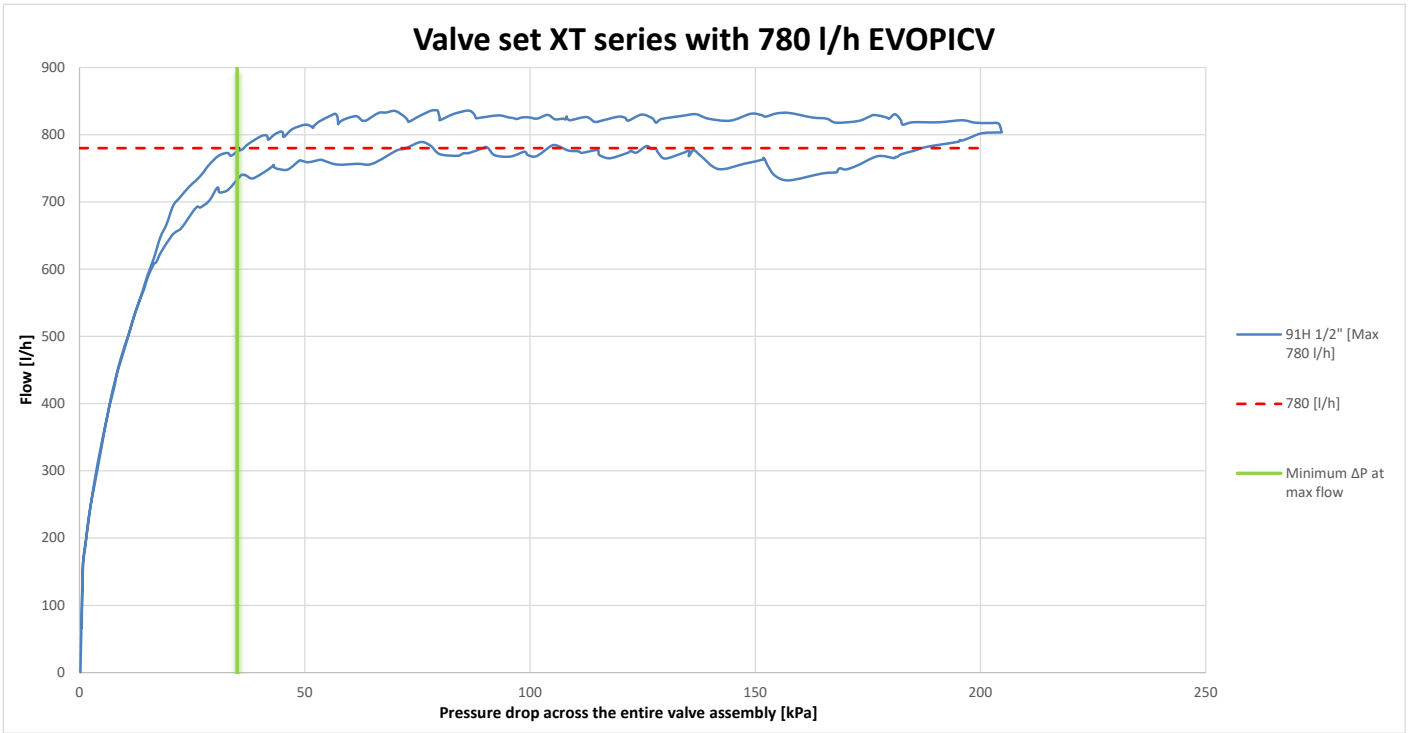

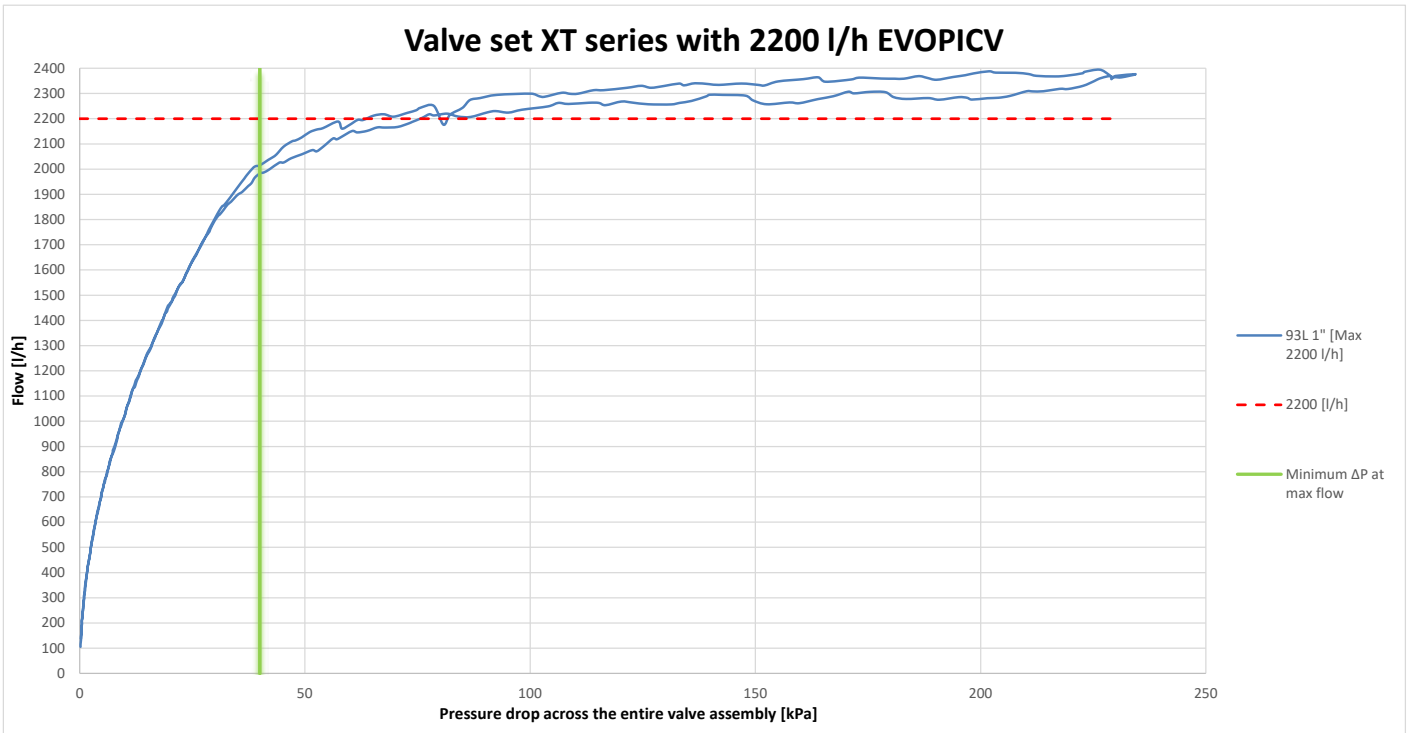
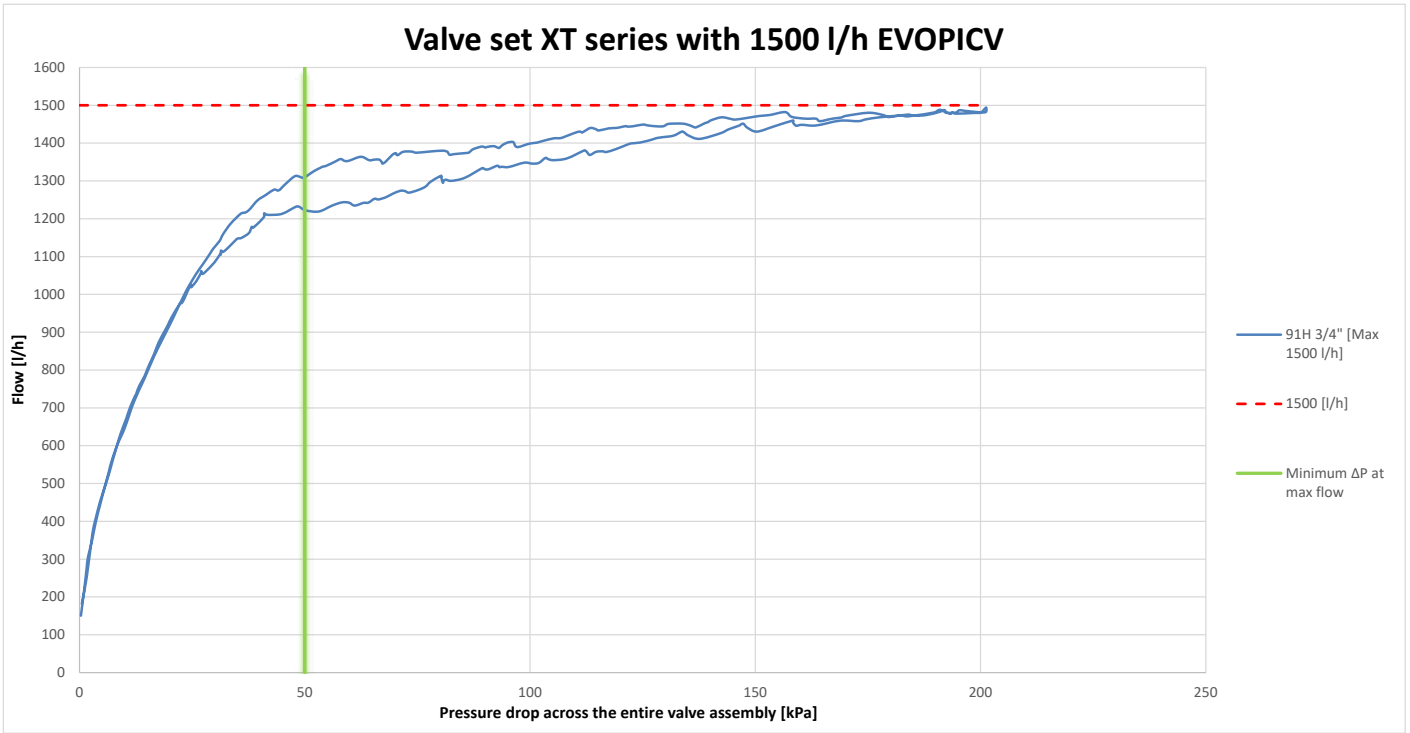

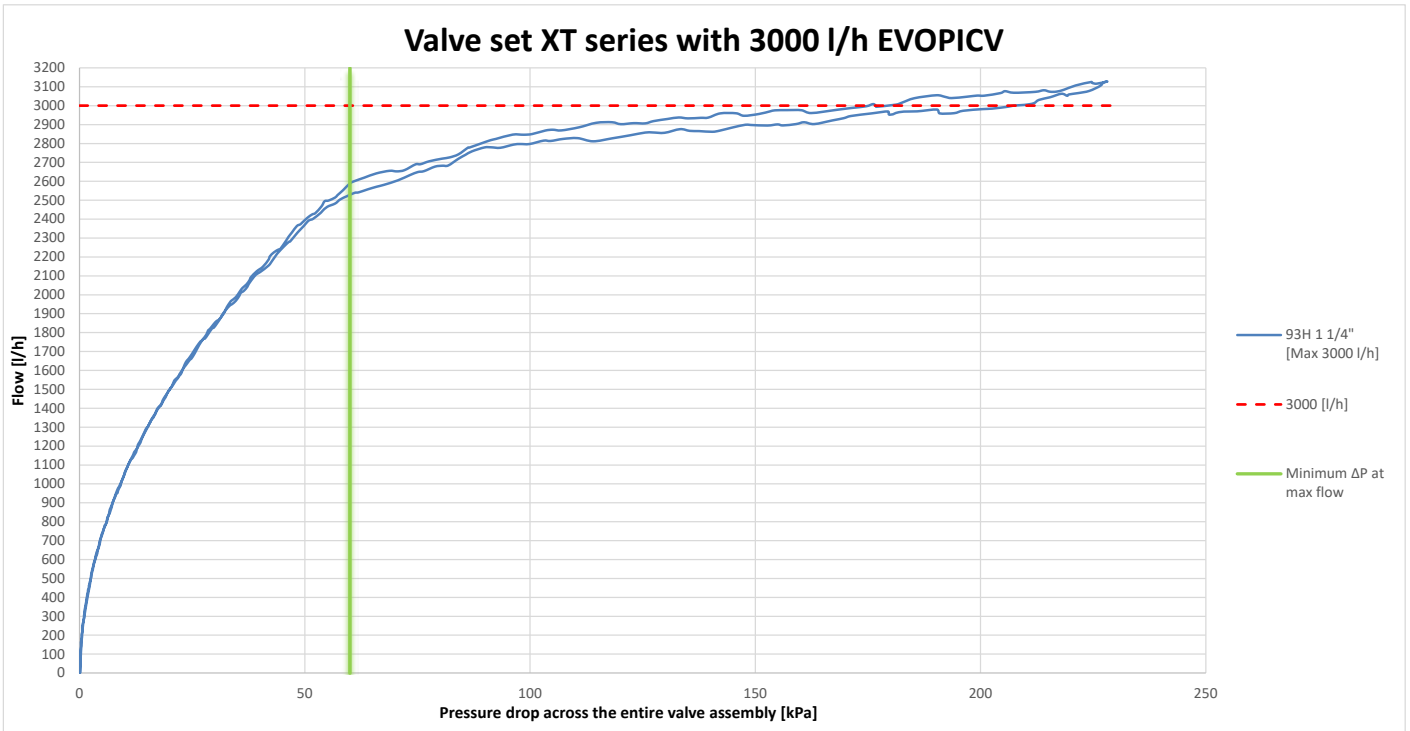
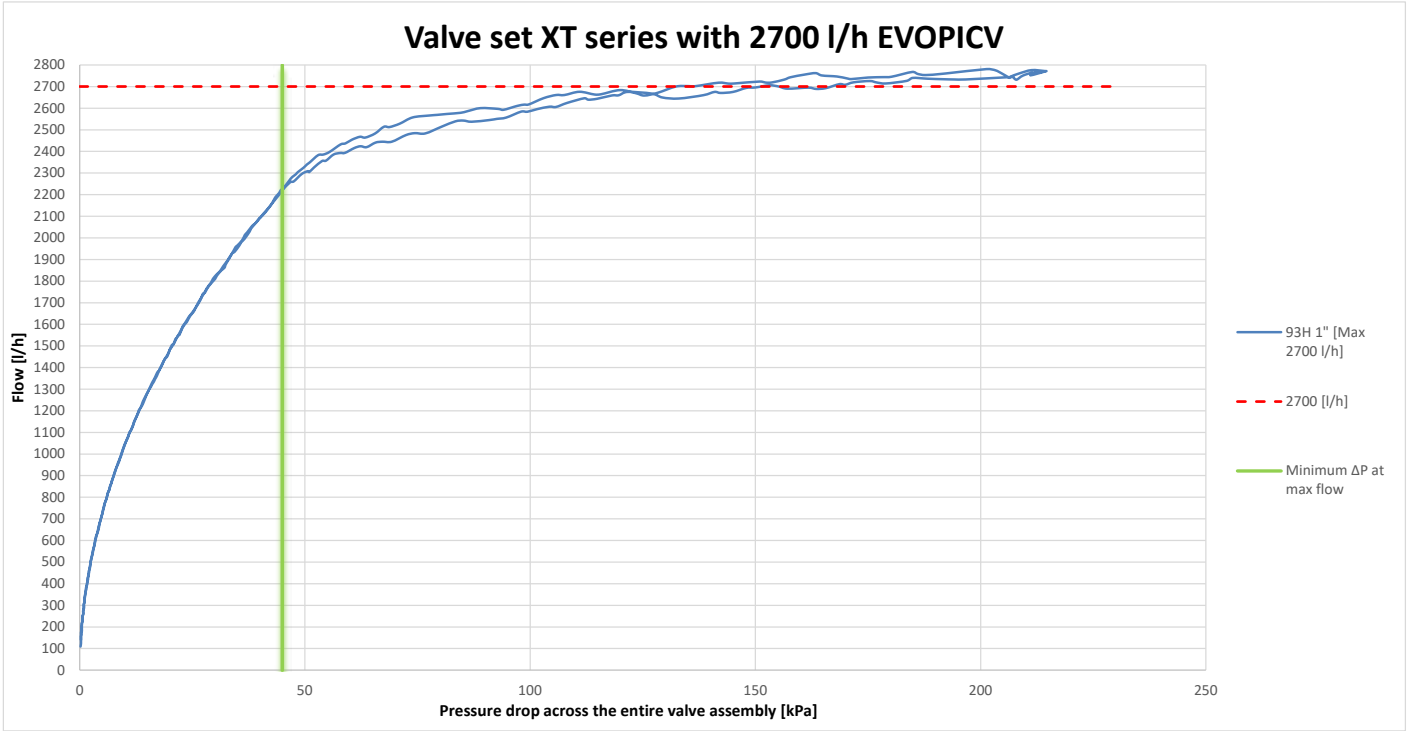

Control valve characteristic

The plot below shows the normalised control valve characteristic when the XT is fitted with the two most common actuator combinations. The VA7482 is a 0-10V proportional actuator and the VA7481 is a 3 point floating type.

Control valve characterisation

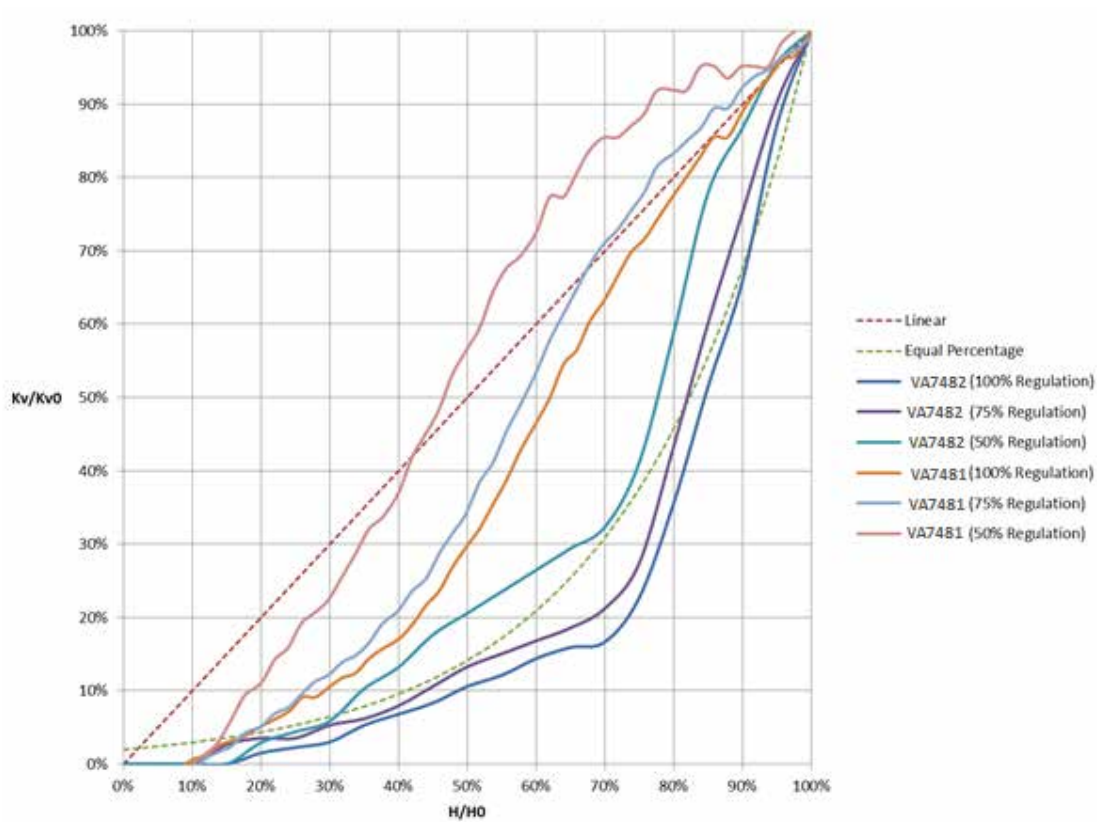

INSTALLATION AND OPERATING INSTRUCTIONS

Installation

Care should be taken when screwing pipe adaptors to the valve set not to over stress the joints, avoiding, where possible, mixing tapered and parallel threads on the same joint. It is also recommend that a liquid pipe sealant or PTFE tape is used in preference to hemp and other fillers.

Fratelli Pettinaroli union connectors incorporate hexagon flats for use with non serrated jawed tools; never use Stilsons or other serrated jawed tools to tighten these or any other brass fittings.

All union nuts in the standard XT are 42mm across flats; female threaded connections have different size: in this case, connection must be carried out blocking the male thread with a counter key. We would recommend the use of a modified flare nut spanner (as detailed below) or a crows foot spanner. Please observe the stated torque requirements when tightening union joints.



30mm Flare Nut Spanner , Modified with 30mm Slot

Always remove any O-rings from solder fittings before applying heat, do not solder union connections in place.

When connecting end fittings to the XT ensure that any torque applied is properly countered so that other connections are not loosened and sealants applied by Fratelli Pettinaroli are not damaged. This can generate leakages.

When opening and closing the drain valve use a cabinet key (square drive) of the correct size, using a spanner of excessive length or grips can damage the internal stops of the valve.

If the kit is not thermally isolated and a drip tray is present, the XT should be properly bracketed to the terminal unit drip tray; the design and construction of the mounting system and ensuring that the drip tray is of sufficient size will be the responsibility of the terminal unit manufacturer. There is a tapped blind hole on the bottom of the flushing by-pass valve intended to facilitate easy and secure bracketing of the valve assembly. This hole size varies in function of the by-pass size: M6 on 40 mm by-pass (XT600, XT601) and 70 mm by-pass (XT700, XT701), M10 on 80 mm by-pass (XT800, XT801, XT850, XT851), ¼"NPT on variable centre to centre distance by-pass.

Care should be taken to avoid galvanic corrosion where there is metal on metal contact.

Media quality

It is expected that the system to which the XT is fitted be pre-cleaned and flushed in accordance to the standards and principles detailed in the BSRIA guide "Pre commission cleaning of pipework systems" (BG29/2012) and the water quality maintained to standards as detailed in BSRIA guide "Water treatment for closed water systems" (BG50/2013) and UNI8065 standard.

The valves used in the XT contain a number of O-Rings, washers and seats made variously of NBR, EPDM, PTFE and FKM, please ensure compatibility of these materials with any water treatments, chemical cleaning agents and other compounds exposed to the media such as pipe sealants.

The XT is intended for use with group 2 non dangerous liquids only (dangerous liquids, group 1, are defined in article 2, paragraph 2 of the Directive 67/548/CEE). Note that it is advisable to get a confirmation from the liquids producers regarding their compatibility with the materials the XT is composed of.

Flushing and isolation

The valve set is configured such that it can be easily flushed out of circuit (by-passed) and also to allow the forward flushing of the connected coil, if a tee with drain is installed: reasons are listed below. The valve set can only be forward flushed to fill and purge the valve with treated water.

- a. So as not to flush dirt through the EVOPICV valve
- b. The EVOPICV valve is a flow limiting valve, by forward flushing through this valve the media velocity may not achieve those needed for an adequate flush

In general the flushing procedure can be performed by those valve settings having the drain and should be as follows:

1. Mains flush
2. Flush to drain
3. Forward flush to fill and purge

Fixed centre to centre distance.

Mains flush

To perform a mains flush

1. Isolate the flow leg using the isolation valve Filterball
2. Open the flushing by-pass valve, so that the handle is perpendicular to the axis of the by-pass inlets, this also isolates the return leg.



Flush to drain

The valve set and attached coil can be back-flushed to drain in order to purge and flush the attached coil. This operation can be performed if a tee with drain is set. It can be done in direct or reverse mode.

The procedure for XT601, XT701, XT801 and XT851 should be as follows:

Forward flush to drain

1. Close the EVOPICV either using the knob provided or by driving the actuator closed.
2. Close the flushing by-pass valve, so that the handle is parallel to the axis of the by-pass inlets.
3. Open the flow isolation valve.
4. After attaching a hose to blow down valve using the supplied hose barb, open the blow down valve.

Be sure to isolate and cap off the blow down valve before returning the valve set to service.



Forward flush to drain from the return

Be sure that the flow direction is inverted in the inlet and outlet pipes to the valve set.

1. Close the EVOPICV either using the knob provided or by driving the actuator closed
2. Open the flushing by-pass valve, so that the handle is perpendicular to the axis of the by-pass inlets. It should still be in this position from the mains flush
3. Open the flow isolation valve
4. After attaching a hose to blow down valve using the supplied hose barb, open the blow down valve

Be sure to isolate and cap off the blow down valve before returning the valve set to service.



Filling and purging

Once the valve set has been back flushed it is prudent to fill the EVOPICV valve with treated water. To do this

1. Close the flushing by-pass valve, so that the handle is parallel to the axis of the by-pass inlets
2. Open the EVOPICV valve
3. Open the blow down valve to allow a small amount of treated water to be drawn into a bucket thus ensuring the entire valve set is full of the treated water
4. Close the blow down valve and ensure that the cap is replaced



Normal operation

The valve set should be configured as follows during normal operation.

1. Return isolation valve is open
2. The flushing by-pass valve is closed, so that the handle is perpendicular with the axis of the valve inlets
3. Any override clutches on the EVOPICV actuator are disengaged, the valve will be positioned as determined by the BMS controller.



Variable centre to centre distance.

Mains flush

To perform a mains flush

1. Isolate the flow leg using the isolation valve Filterball
2. Open the flushing by-pass valve.
3. Isolate the return leg using the isolation ball valve.

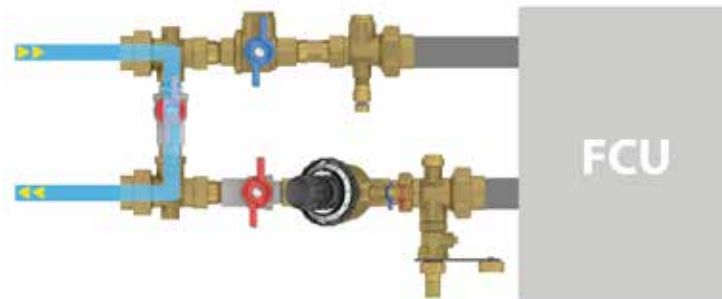

Flush to drain

The valve set and attached coil can be back-flushed to drain in order to purge and flush the attached coil. This operation can be performed if a tee with drain is set. It can be done in direct or reverse mode.

The procedure should be as follows:

Forward flush to drain

1. Close the EVOPICV either using the knob provided or by driving the actuator closed.
2. Close the flushing by-pass valve.
3. Open the flow isolation valve. Close the return isolation valve. It should still be in the position from the main flush.
4. After attaching a hose to blow down valve using the supplied hose barb, open the blow down valve.

Be sure to isolate and cap off the blow down valve before returning the valve set to service.

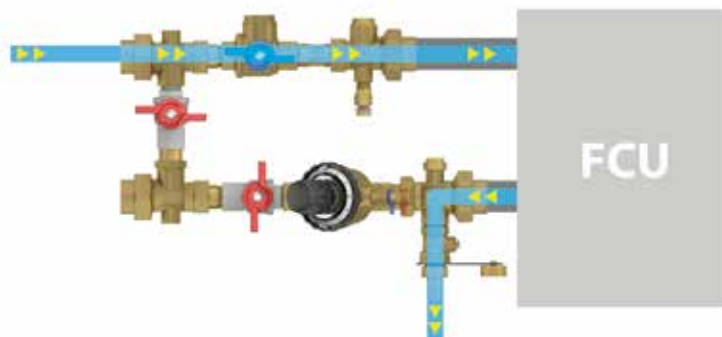

Forward flush to drain from the return

Be sure that the flow direction is inverted in the inlet and outlet pipes to the valve set.

1. Close the EVOPICV either using the knob provided or by driving the actuator closed
2. Open the flushing by-pass valve and close the return isolation ball valve. It should still be in this position from the mains flush
3. Open the flow isolation valve
4. After attaching a hose to blow down valve using the supplied hose barb, open the blow down valve

Be sure to isolate and cap off the blow down valve before returning the valve set to service.

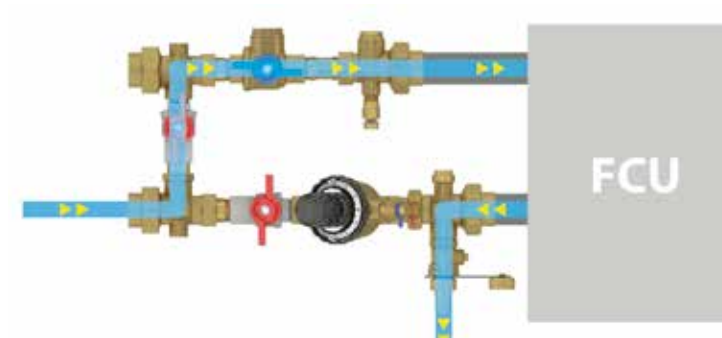

Filling and purging

Once the valve set has been back flushed it is prudent to fill the EVOPICV valve with treated water. To do this

1. Close the flushing by-pass valve.
2. Open the EVOPICV valve
3. Open the blow down valve to allow a small amount of treated water to be drawn into a bucket thus ensuring the entire valve set is full of the treated water
4. Close the blow down valve and ensure that the cap is replaced

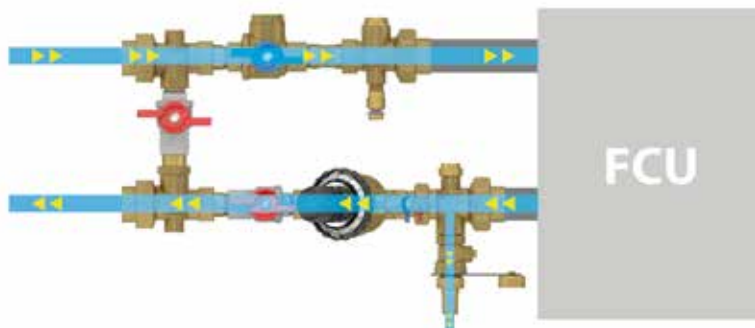

Normal operation

The valve set should be configured as follows during normal operation.

1. Flow and return isolation valve is open.
2. The flushing by-pass valve is closed.
3. Any override clutches on the EVOPICV actuator are disengaged, the valve will be positioned as determined by the BMS controller.

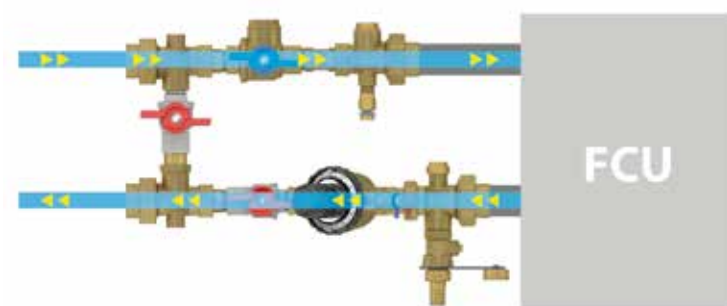

Setting and commissioning

For more information on commissioning PICV systems please see *Fratelli Pettinaroli' Definitive Guide to Pressure Independent Control Valves*.

The Flow rate can be set by adjusting the black hand-wheel on the EVOPICV to the required position.

The set position is expressed as a percentage of the EVOPICV valve's maximum flow rate and is calculated by dividing the design flow by the maximum nominal flow of the valve and multiplying by 100.

$$\text{Setting} = \frac{\text{Design flow rate}}{\text{Valve maximum flow rate}}$$

For example where the design flow rate is 450 l/h and the valves maximum flow rate is 600 l/h there are two main approaches to commissioning the valve assembly.

$$\text{Setting} = \frac{450}{600} = 75\%$$

Pre-setting

With the valve set in the normal operating mode the EVOPICV can then be pre-set to the calculated position as detailed on the selection schedule.

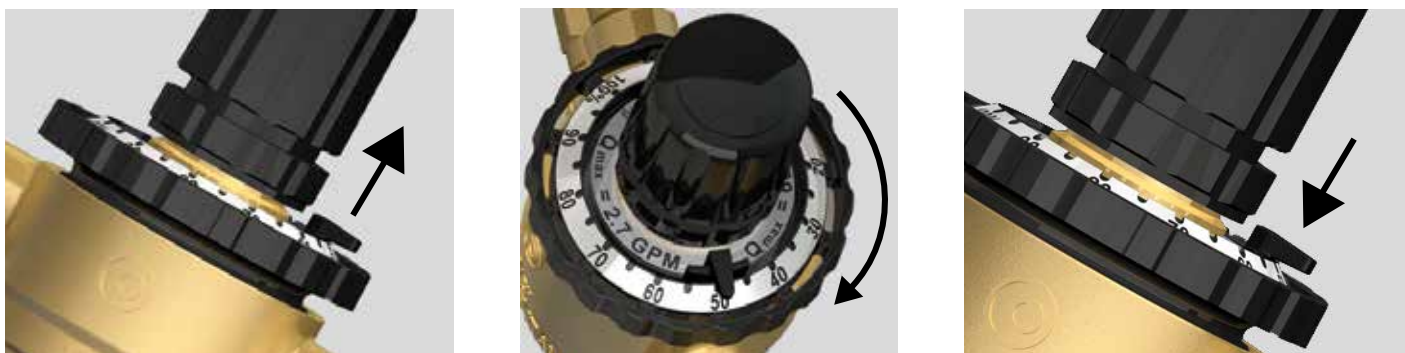

Lift the lock pin to unlock the hand-wheel. The hand-wheel is graduated from 100% to 10%, turn the hand-wheel to the calculated percentage as indicated by the lock pin. Press the lock pin to lock the hand-wheel in position.

When the valve is pre-set there will be a wider variation in measured results compared to if the valve was set to a flow rate using the venturi flow measurement device according to start-up diagrams on technical manual of EVOPICV.

Setting to a flow rate

With the manometer connected to the flow measurement station the pre-setting wheel can be adjusted until the correct differential pressure measurement is achieved according to start-up diagrams on technical manual of EVOPICV.

The set position should be recorded on the commissioning documentation along with the manometer readings and flow rate. Deviations of more than 15% from the calculated set position should be cause for investigation as they may indicate problems with the local installation or the PICV.

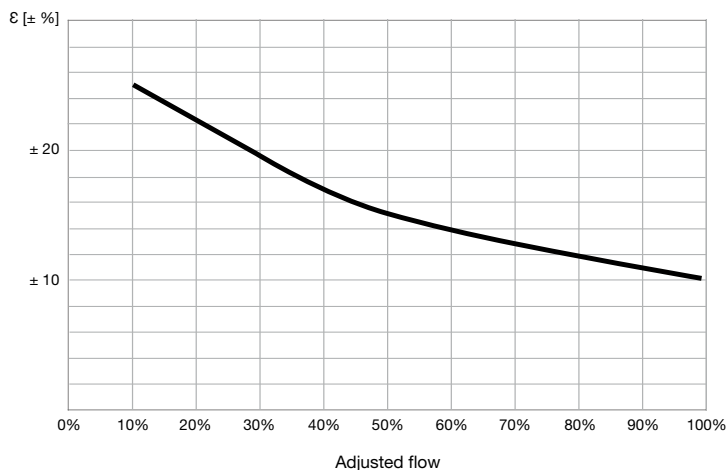

Setting Accuracy vs Hand Wheel Position

Flow and differential pressure measurements

The XT valve assembly can be come equipped with multiple pressure temperature readout ports. These are all of the binder type. With regard to those valve sets which have a tee with additional pressure gauge, all the pressure ports allow for the following measurements to be taken:

- a. Differential pressure or temperature across terminal unit
- b. Differential pressure across EVOPICV valve
- c. Static pressure or temperature at the terminal unit

If a venturi flow measurement device is added, flow rate through the terminal unit may be measured.

Differential pressure across the terminal unit

Connect the low pressure side of the measuring instrument to the high pressure tapping on the EVOPICV and the high pressure side to the tee pressure gauge or to low pressure tapping on the venturi measuring device, when it is installed.

Differential pressure across the EVOPICV valve

If the EVOPICV has both of it test points fitted then simply connect the measuring instrument to these test points. The high and the low side are indicated by the letters H and L in the body forging.

Please note that flow rate cannot be measured across the EVOPICV valve, if a flow rate is required always use the venturi.

To measure the flow rate passing through the terminal unit

Connect the measurement instrument (U-tube manometer or electronic manometer) to the venturi flow measurement device, being sure to purge the pressure lines. Use the stated Kvs to calculate the flow rate based on the differential pressure reading taken and the following formula:

$$Q = (\sqrt{\Delta P} \cdot Kvs) / 36 \quad \text{if } Q = \text{volume flow rate in l/s} \quad \text{or} \quad Q = 100 \sqrt{\Delta P} \cdot Kvs \quad \text{if } Q = \text{volume flow rate in l/h}$$

Kvs = Valve factor as stated on the valve tag or schedule

ΔP = Differential pressure measurement in kPa

Maintenance

The valve set is maintenance free as far as regular service requirements, however the valve assembly can facilitate some maintenance activities. If there are any specific requirements e.g. for the end fittings these will be detailed on supplementary sheets.

It should be noted that when in the closed position (by pass handle perpendicular with the axis of the by-pass inlets and isolation valve closed), the flushing by-pass valve still allows water to by-pass through the connecting loop. Leaving the valve in this position is not recommended when a system has been balanced and is in service as it will provide an uncontrolled water way and potentially affect the balance of the system. If a particular coil is to be taken out of service for an extended period of time then the valve set should be isolated using the flow isolation valve only. The EVOPICV can then be driven to a fully closed position by the actuator or manual protection cap. Alternatively it is possible to fully isolate the terminal legs of the by-pass by closing the isolation valve and removing the handle of the by-pass when the valves are in the closed position. The ball may then be manually rotated 180°. The XT valve set with variable centre to centre distance by-pass allows easier operation: to fully isolate the terminal legs, just close two isolation valves on the return and flow legs; the by-pass isolation valve has to be closed too. Although the flushing by-pass valve will also isolate the flow leg it will simultaneously open the by-pass which may mean that the by-pass circuit itself becomes the most favoured loop on a circuit. This could result in the entire floor being put out of balance.

Replacement of the terminal unit

The valve set is installed with unions or hose pipes at the coil end. These unions allow the coil unit to be removed whilst leaving the valve set in situ to isolate the pipework. To dismantle these unions please ensure

1. That the flow leg isolation valve is closed and that the by-pass valve is opened isolating the return leg
2. The EVOPICV valve is closed, either by the BMS controller or by means of the override clutch on the actuator
3. The unions (when provided) require a 42mm spanner whereas use the suitable spanner to loosen flexible hoses unions
4. Replace the coil as per the manufacturer's instructions
5. If the coil connection blocks and O-rings are serviceable after they have been dismantled then they may be replaced onto the new coil unit, otherwise contact Fratelli Pettinaroli for replacements

Replacement of the diaphragm of EVOPICV 91 valve - 091SET maintenance kit

For further information please refer to instruction 208 - 091SET

091SET maintenance kit

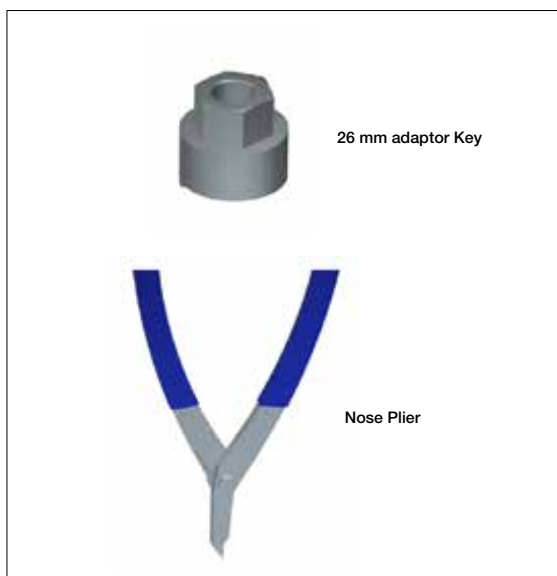

Step 1a: remove completely the knob

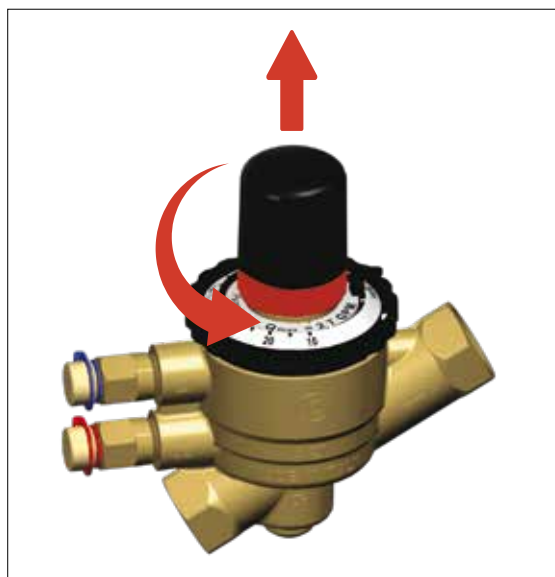

Step 1b: remove the actuator and the adapter.

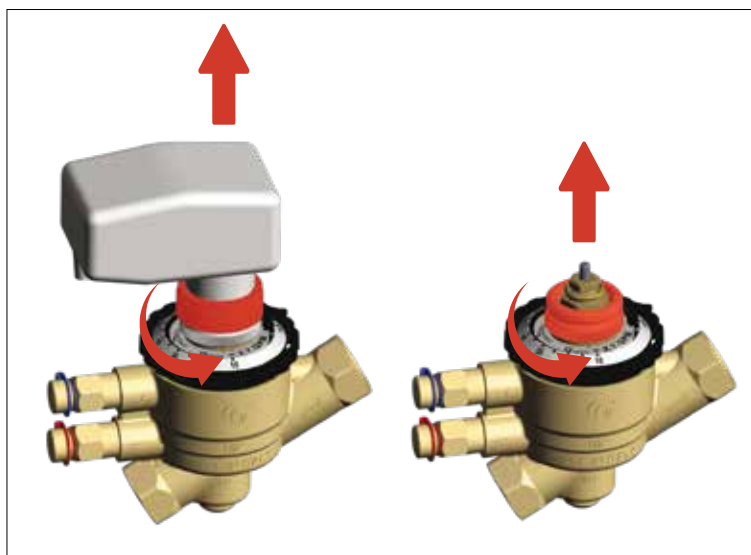

Step 2: using the 26mm adaptor key provided to remove the headwork. Align latches.

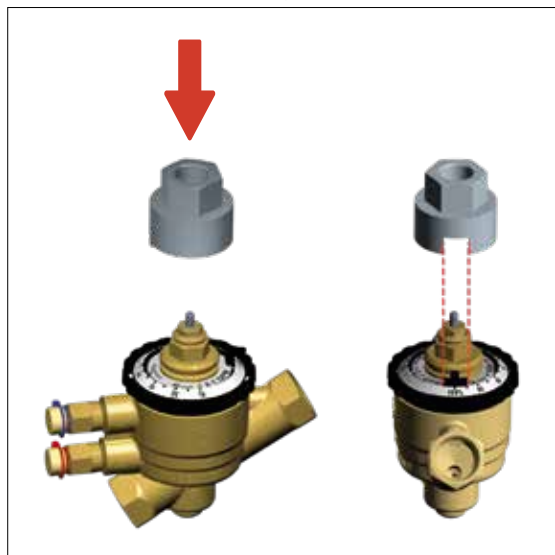

Step 3: using a 26mm spanner unscrew the headwork.

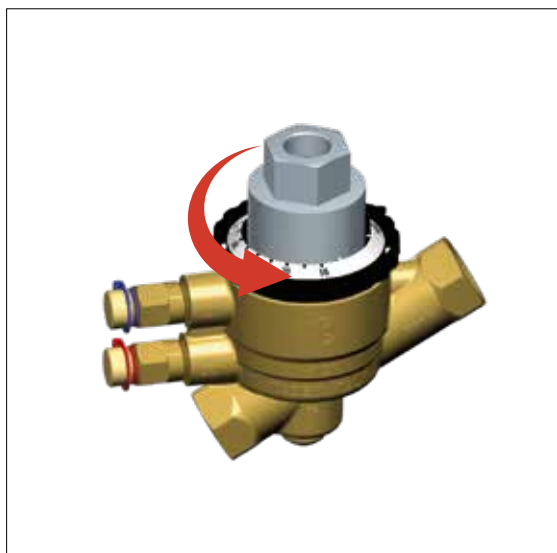

Step 4: remove the headwork.

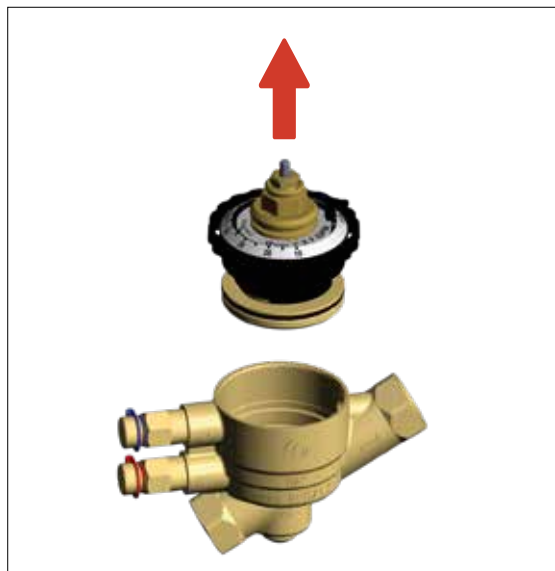

Step 5: Insert the nose pliers through the center of the cartridge



Step 6: press the plier and pull the cartridge up out of the body

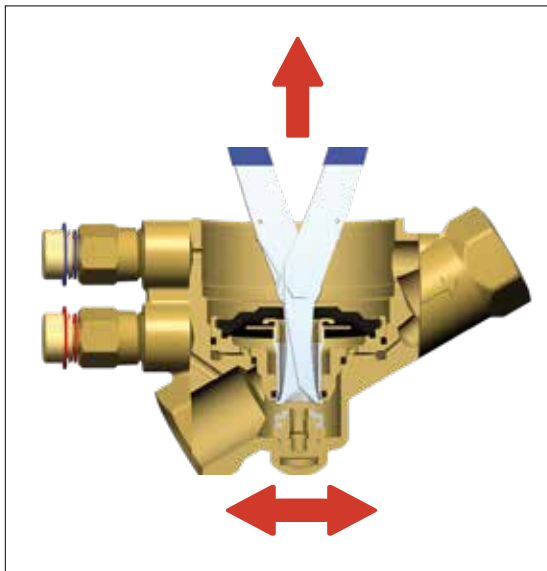

Step 7: Insert the new cartridge

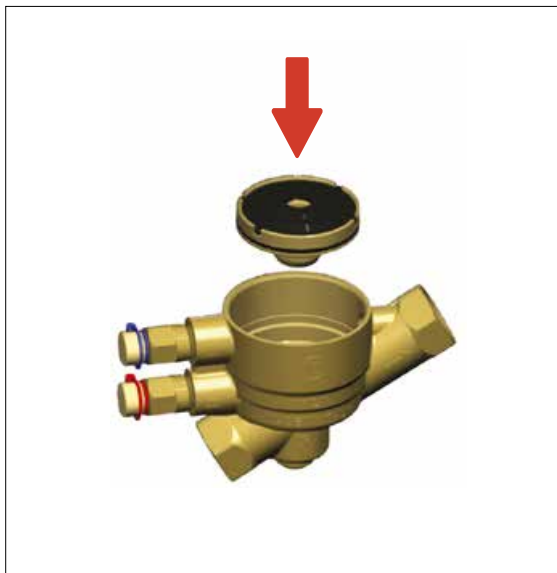

Step 8: Replace the headwork

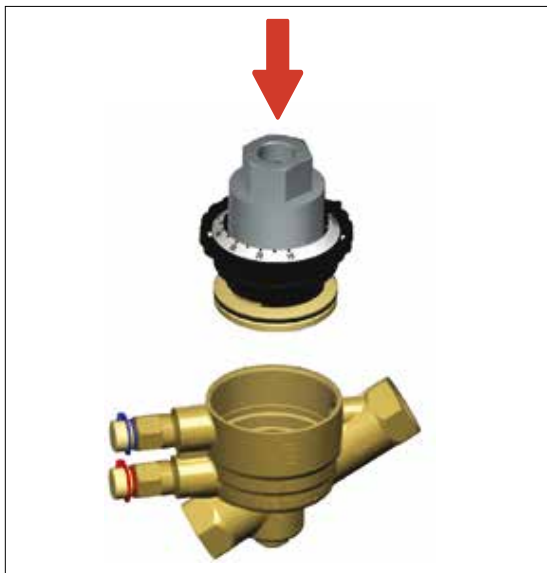

Step 9: Screw the headwork with 15/20 Nm torque reaching the initial position of the lock pin

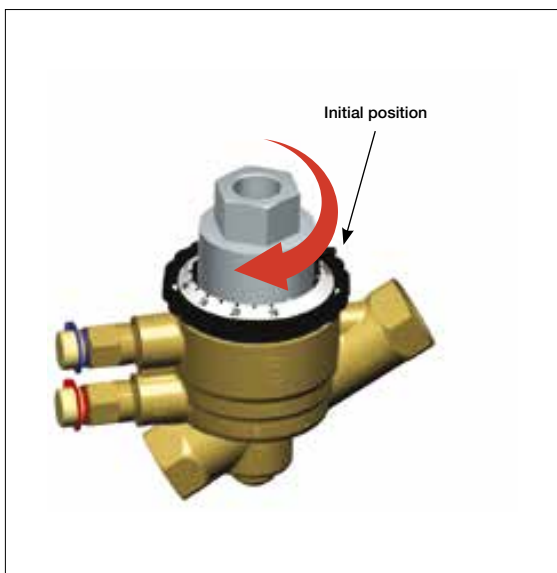

Step 10: remove the 26 mm adapter key and replace the actuator a adapter

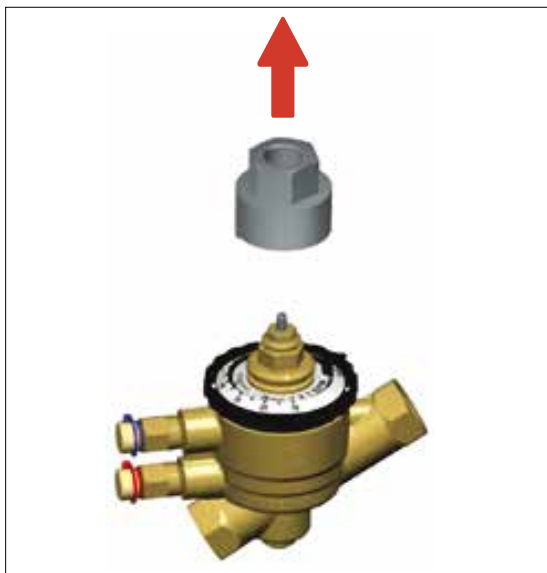

Replacement of the diaphragm of EVOPICV 93 valve

Step 1: unscrew bottom cap



Step 2: unscrew the Diaphragm using an hexagonal socket wrench



Step 3: manually pull out the diaphragm. Push the new one in and follow the instruction in reverse. Wear gloves.

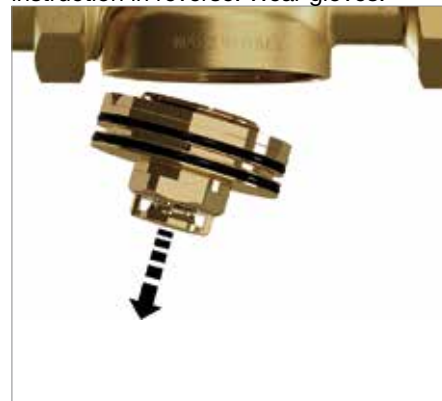

Replacement parts

Every maintenance action must be done by qualified technician, prior communication to Fratelli Pettinaroli. For any request and doubt, please contact the manufacturer.

Main parts in the XT can be field replaced; a 1/2" control valve may be exchanged for a 3/4" or 1" one and vice versa. Care must be taken if the control valve is exchanged for another variant that the matching venturi is also installed (when provided). Every time a technician modifies configuration or replaces a component or a spare part, Fratelli Pettinaroli cannot ensure the watertight seal of the kit.

Replacement of EVOPICV valve (just when a drain is provided)

Should the EVOPICV need to be replaced for any reason this can be accomplished by

1. Closing the flow leg isolation valve
2. Open the flushing by-pass valve, so that the handle is perpendicular to the axis of the by- pass inlets. This will also isolate return leg
3. After attaching a hose union and hose to the blow down valve (when provided), open the blow down valve and carefully release the pressure within the coil. Drain as much of the contents off as possible into a bucket before commencing other works
4. The EVOPICV can be removed by loosening the union joints at the tee end and by-pass end of the EVOPICV valve
5. Remove old EVOPICV
6. Install new EVOPICV by following the instruction in reverse. Fill the system following the procedure "Filling and purging". Be sure the system does not show any leakage

For convenience, EVOPICV and union tails will be replaced as a unit.

INDIVIDUAL COMPONENTS

EVOVICV

For more information on commissioning PICV systems please see *Fratelli Pettinaroli' Definitive Guide to Pressure Independent Control Valves*.

One of problems associated with 2 port control is sizing and making sure all of the control valves have adequate authority. Whilst this problem is helped by the use of differential pressure controllers it can still be difficult to maintain good authorities without specifying that each terminal unit requires a DPCV. Using traditional valves this would be a very expensive design approach.

The pressure independent control valve (PICV) combines the functions of a differential pressure controller, regulation valve and 2 port control valve into a single body.

The EVOVICV incorporates a small diaphragm type DPCV in order to keep a constant differential pressure across an orifice and to provide a constant flow rate whilst the differential pressure is with the operating limits of the valve. Beyond these working pressures the valve acts as a fixed orifice.



EVOVICV 91 valve.

Component	Material
Body	DZR BRASS CW602N (EN 12167)
Headwork	BRASS CW614N (EN 12164)
Cartridge sleeve	Stainless Steel
Diaphragm	BRASS CW614N - High resistance EPDM
O-Rings	EPDM-X
Adjustment ring	PSU
Connections	1/2" F - 3/4" F - 1" F



EVOVICV 93 valve.

Component	Material
Body	DZR BRASS CW602N (EN 12167)
Headwork	BRASS CW614N (EN 12164)
Cartridge sleeve	Stainless Steel
Diaphragm	BRASS CW614N - High resistance EPDM
O-Rings	EPDM-X
Adjustment ring	PSU
Connections	3/4" Union End - 1" Union End - 1 1/4" Union End

Making this orifice adjustable allows the valve to be pre-set deliver a range of flow rates. In the case of the EVOPICV valve this adjustment can be made in situ without removing any covers or actuators, the adjustment wheel is lockable by means of a combined memory stop and indicator.

The EVOPICV valve also includes 2 port temperature control by means of an oblique pattern globe valve. The plug of the globe valve is machined to give a near equi-percentage flow control characteristic. Due to the fact that the differential pressure across the valve seat is constant it can be said that the authority of this control valve is very close to 1.

The EVOPICV can be fitted with a range of actuators including thermo-electric ON/OFF, modulating actuators and motorised actuators. When shut tight, the globe valve is a metal on metal seal and as such the leakage rate should be no more than 0.01% of the nominal maximum flow of the valve as defined by class IV of IEC60534-4.

Due to the way the EVOPICV valve controls the flow rate, irrespective of differential pressure branch and sub mains, balancing valves are not required. The flow rate is maintained at the terminal unit regardless of system conditions making the valve ideal for systems with inverter driven pumps.

Characteristic	
Pressure rating	PN25
Flow rate range	0.004 – 0.75 l/s dependent on valve selection
Working differential pressure range	20 – 600kPa minimum depends on valve and setting, valve will operate up to 600kPa, 400kPa is recommended to avoid unwanted noise
Accuracy (linearity and hysteresis)	±5% till 1 bar DP, ±10% over 1 bar DP at 100% flow
Leakage rate to IEC 60534-4	Class IV

Filterball strainer

The strainer basket is mounted in the ball of the isolation valve itself; a side mounted inspection port allows the strainer basket to be removed for cleaning and maintenance without the need for additional isolation valves. Both steel and aluminium butterfly handles are available.



51F

The Filterball is machined from a hot forged DZR brass body, the seats are virgin PTFE and the stem is sealed by a pair of Viton O-Rings in addition to a PTFE gland. As standard the Filterball comes fitted with a 700 micron (28 mesh) strainer basket, grades as coarse as 800 micron and as fine as 150 microns are available as optional extras.

Component	Material
Body	DZR BRASS CW602N (EN 12167)
Ball	CHROME PLATED DZR BRASS CW602N (EN 12167)
Insert	DZR BRASS CW602N (EN 12167)
Stem	DZR BRASS CW602N (EN 12164)
Seats	PTFE
O-Rings	FKM
Strainer basket	STAINLESS STEEL
Circlip	POSPHOR BRONZE

Characteristic	
Pressure rating	PN25
Strainer size	700 micron (28 Mesh)
KV	7 (DN15) and 7.5 (DN20)
Size	DN15 and DN20
Connections	1/2" F - 3/4" F

Coil connection tee

The coil connection set is intended to provide a simple way of connecting the XT unit to the terminal coil tails, when provided. The coil connection tee 1020 and 1020P can be configured with male and female end connections. It has ports for a drain and optional accessory such as an air vent, test plug or cap. The final function of the coil connection tee is to provide a union joint at a position where the coil could be removed whilst the bulk of the XT remains connected to the pipework providing isolation.

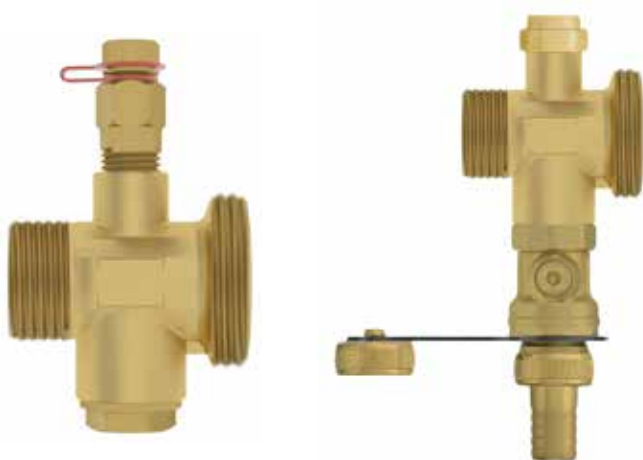

Component	Material
Body	BRASS CW617N (EN 12165)

Coil connection tee with various accessories

Characteristic	
Pressure rating	PN25
Connections	3/4" E x 1 1/8"
Blow down connection	1/2" F
Air vent / Pressure gauge connection	1/4" F NPT

Blow down valve

The blow down valve is of the ball type, the handle is of the square drive type and may be opened and closed using a 7mm square drive or spanner, shut off is positive. The connection to the XT is sealed by use of an O-ring. A cap and 14.5mm hose barb are included.



Component	Material
Body	BRASS CW617N (EN 12165)
Ball	TEA PLATED BRASS CW617N (EN 12165)
Insert	BRASS CW614N (EN 12164)
Seats	PTFE
Stem O-Rings	FKM
Stem	BRASS CW614N (EN 12164)
O-Ring	EPDM

Characteristic	
Pressure Rating	PN25
Connections	1/2" M

Flushing by-pass

BSRIA application guide “Pre-Commission cleaning of pipework systems” recommends that all terminal units are fitted with fixed flushing by-passes. This BSRIA guide is referenced in the CIBSE code W “Water Distribution systems”.

The XT valve set series is equipped with three different types of flushing by-pass:

- 40 mm centre to centre distance by-pass valve XT3BP DN20
- 70 mm centre to centre distance by-pass valve XT7BP
- 80 mm centre to centre distance by-pass valve XT3BP DN25
- Variable centre to centre distance by-pass set (130 mm to 300 mm)

The Fratelli Pettinaroli flushing by-pass valve has been designed for all types of hydronic terminal unit.

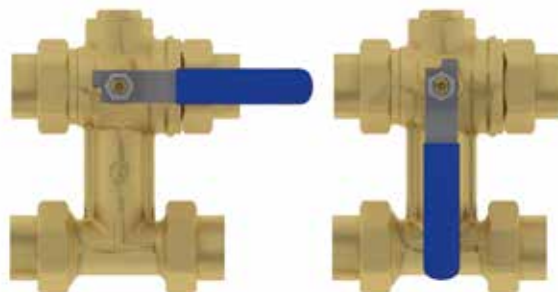

Main Flush



Operating Mode



Forward flush from the return



Material	XT3BP DN20	XT3BP DN25	XT7BP
Body	BRASS CW617N (EN 12165)	BRASS CW617N (EN 12165)	CR BRASS CW602N (EN 12165)
Balls	TEA PLATED BRASS CW617N (EN 12165)	CHROME PLATED BRASS CW617N (EN 12165)	TEA PLATED BRASS CW614N (EN 12165)
Insert	BRASS CW617N (EN 12165)	BRASS CW617N (EN 12165)	BRASS CW617N (EN 12165)
Seats	PTFE	PTFE	PTFE
O-Rings	FKM	FKM	FKM
Stems	BRASS CW614N (EN 12164)	BRASS CW614N (EN 12164)	BRASS CW614N (EN 12164)

The by-pass valve XT3/XT7 comprises of two through connections joined by a perpendicular by-pass section. The top connection does not incorporate any ball valve, the bottom through section contains a three ported ball valve which allows for two operation modes - by-pass and flow. These flow sections are arranged at three distances as mentioned before: 40mm centres which is increased up to 60 mm by means of two eccentrics in order to be directly installed on 60mm centre inlet/outlets terminal units; 70mm and 80mm centres so as to provide a way to directly mount any valve set to a fan coil unit with matching 70mm or 80mm centre inlet/outlets.

The bottom ball valve has three ports machined in a T configuration. In flow mode, the middle port is sealed against the third and fourth seats preventing water from flowing through the by-pass. As the valve is moved into by-pass mode the outlet side of bottom return connection is isolated whilst the by-pass connection is opened allowing the two inlet connections to be flushed through.

Connections to pipe line are female in XT3BP DN20 and female union end in XT7BP and XT3BP DN25.

Characteristic	XT3BP DN20	XT3BP DN25	XT7BP
Pressure rating	PN25	PN25	PN25
Bore Ø (flow mode) [mm]	15	25	15
Bore Ø (by-pass mode) [mm]	10	20	10
Connections	½"F x ¾"E	¾"F union end	½"F/¾"F union x ¾"E

The variable centres by-pass is a set of components. It comprises of two through tees connections 1020 joined by a perpendicular by-pass section made by a two ports isolation ballvalve 52/1 and a pipe section. The brass pipe which constitutes the variable length element is 3 mm thick. The top leg does not meet any ball valve before the Filterball valve, the bottom through section is followed by an isolation 2 ports ball valve. The combined action of those three ball valves allows for two operation modes - flushing and flow. These flow sections are arranged at variable centre distances, as mentioned before: from 130 mm, any distance can be get until 300 mm.

In flow mode, the by-pass pipe is sealed by the specific ballvalve which prevents water from flowing through the by-pass. As the by-pass valve is moved into by-pass mode (it is opened) and the return leg ball valve is closed, the outlet side of bottom return connection is isolated whilst the by-pass connection is opened allowing the two inlet connections to be flushed through. Connections to pipe line are female 3/4" or 1" female union end.

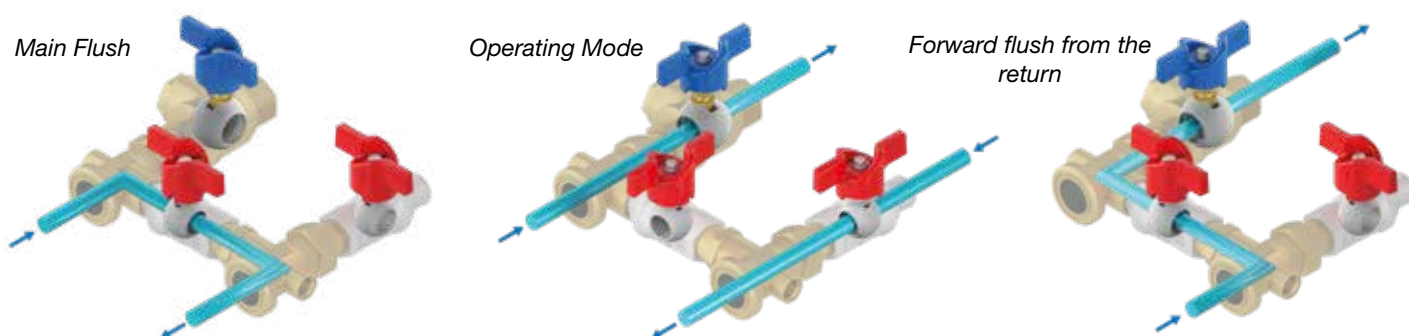

Component material	Pipe	1020	52/1
Body	BRASS CW614N (EN 12164)	BRASS CW617N (EN 12165)	BRASS CW617N (EN 12165)
Balls	-	-	TEA PLATED BRASS CW617N (EN 12165)
Insert	-	-	BRASS CW617N (EN 12165)
Seats	-	-	PTFE
O-Rings	-	-	FKM
Stems	-	-	BRASS CW614N (EN 12164)

Characteristic	By-pass
Pressure rating	PN25
Bore size (flow mode) [mm]	15
Bore size (by-pass mode) [mm]	15
Connections	1/2" M x 3/4" F union end

Venturi flow measurement (optional)

The Terminator Interchangeable venturi housing is based on the proven venturi inserts used in our Terminator commissioning valve. The same venturi inserts are used but we have recalculated the Kvs values in situ in its specific housing, this means that each venturi is calibrated for the exact situation in which it is used.



Interchangeable venturi flow measurement device

Component	Material
Body	DZR BRASS CW602N (EN 12165)
Venturi insert	BRASS CW614N (EN 12164)
Test point	BRASS CW617N (EN 12165)
Test point core	Ethylene propylene rubber EPDM
O-Rings	EPDM

Characteristic	
Pressure rating	PN25
Connection	1/2" M x 1/2" F and 3/4" M x 3/4" F
Working differential pressure range	1.5 – 15kPa
Accuracy (linearity)	±5% across working DP range

Sizing of the venturi is usually carried out to give differential pressure readings between 2 and 10kPa as this is the most accurate range of the venturi but also allows digital manometers to be used.

The venturi allows high signals of up to 15kPa to be achieved without significant residual pressure loss.

The Terminator interchangeable venturi housing is machined from a hot forged DZR brass body.

The venturi insert fitted will be identified by a coloured band on the high pressure test point. This all gives a quick guide to main Venturi insert and control valve selection. Other Venturi inserts are available for very high flow rates.

Venturi size	Colour
3 mm	WHITE
4.25 mm	GREEN
6 mm	ORANGE
7.5 mm	BLUE
9 mm	YELLOW
10.5 mm	RED

Flow measurement chart

The chart below plots the Kvs of the various venturi inserts when installed in the complete valve assembly. The selection boundaries are also shown on the chart, the green bars show the typical range of flow rates that each venturi can be selected to measure (between 2 and 10 kPa). The red bars show the maximum useful range of the venturi, readings beneath 0.5kPa will not be as accurate, and above 15kPa the intrinsic pressure loss of the venturi will be too high.

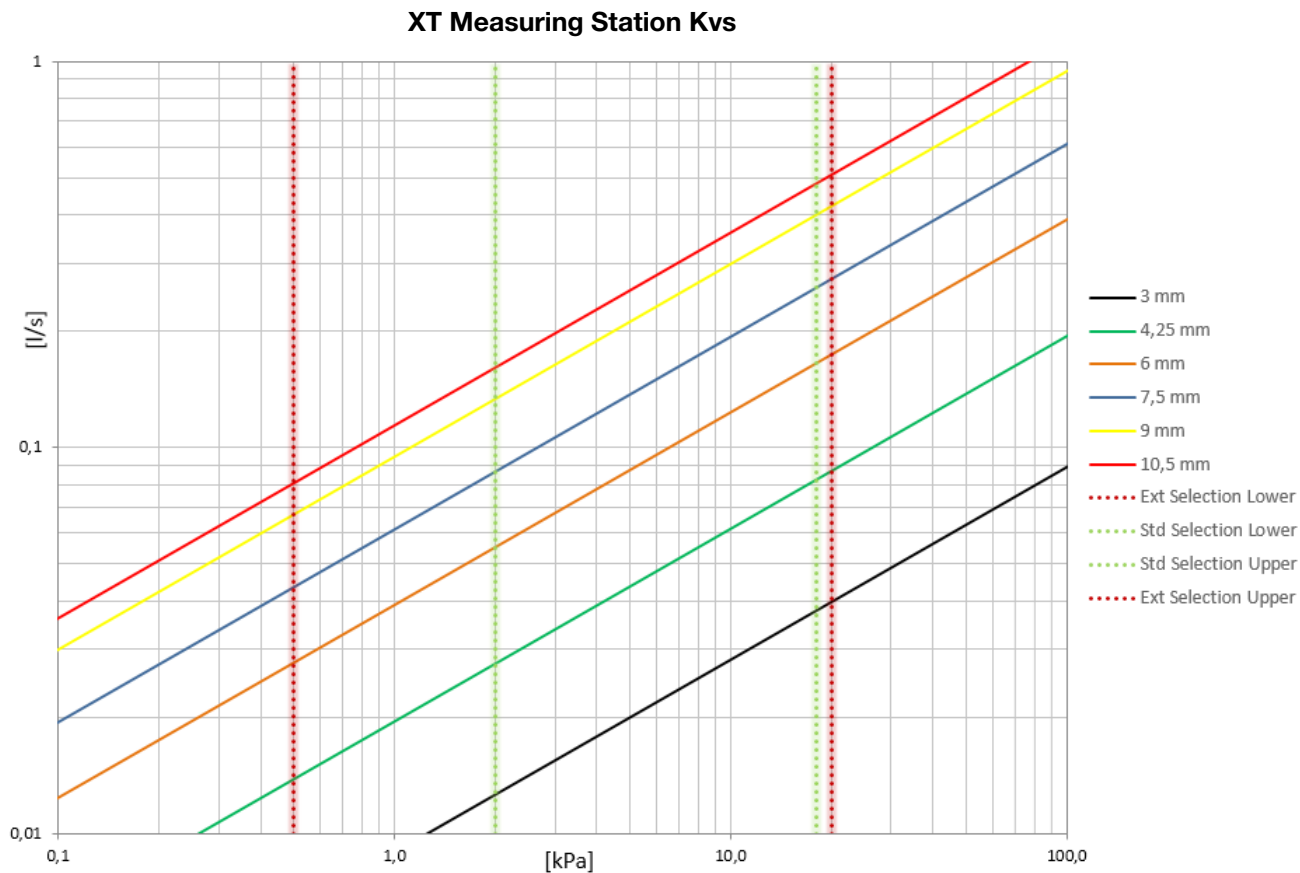

Replacement of venturi

The venturi can be replaced in the field; for convenience the entire venturi housing and insert along with the inlet union tail will be replaced as a unit. To replace the venturi

1. Isolate flow and return isolation valves
2. The EVOPICV valve is closed, either by the BMS controller or by means of the manual knob.
3. Use blow down valve to de-pressurise and drain the terminal
4. The union nuts require a 30mm spanner, a modified flare nut or crows foot spanner is recommended
5. Loosen the front and back union nut on the flow leg
6. Remove old venturi housing
7. Install new venturi housing by following the instructions in reverse. Be sure the system does not show any leakage

Union connections

Union connections are machined from hot forged brass billets. Both female and male union connections are available. Female ones can be selected between BSP and NPT type.



Component	Material
Body	BRASS CW617N (EN 12165)
Nut	BRASS CW617N (EN 12165)
O-Rings	EPDM
Connection	1 1/8" union end x 1/2" F - 3/4" F - 1" F

Insulating case (optional)

The XT valve assembly series has a complete range of insulating cases for heating and cooling. Insulation guarantees high energy savings by reducing heat losses throughout pipe lines: in this way energy carrier reaches terminals with most suitable temperature. Moreover, insulation must be placed on cooling systems to avoid also condensation on pipes and valves which may damage structural elements, false ceilings and decorative items.

Cases can be ordered separately or they can be delivered along with kits. They are properly customized on valve set size and shape. Both type of cases for heating and cooling are 20mm thick and they are made by polyethylene cross linked foam. What it changes between cooling and heating cases is the insulation of the actuator: indeed, cooling cases are delivered with an additional case which has to be fit onto the actuator whereas heating variants are devoid of that. In this way, heat exchange is promoted by the actuator side during the heating season whereas the actuator little case prevents actuator failures due to condensate drip.

Cases are supplied as two shells, upper and lower parts, which are held together by tape; Fratelli Pettinaroli can provide two type of tape to be chosen between Velcro® and the cheaper double-side adhesive tape. If needed, other mounting configurations are available on demand. Insulating shells should be installed after commissioning. Union connections, the actuator connection and all the coupling line between shells should be insulated by using thermal tape.



Insulating case	Features
Material	Polyethylene cross linked foam
Density [kg/m3] x thickness [mm]	30 x 15mm + 80 x 5mm
Thermal conductivity [W/m K]	0.04 (density 30 kg/m3)
Fire resistance (UNI8457, UNI 9174)	Class 1
Operating temperature	-60 ÷ + 90°C

Flexible hoses (optional)

Despite Pettinaroli valve assembly XT series covers an extremely wide range of centre distances, inlet pipes and coil connections may have various distances so as flexible hoses are needed to connect the assembly to any pipe.

Fratelli Pettinaroli's flexible hoses are all EPDM flexible pipes protected by stainless steel twist. Connection ends are made by machined brass. Fratelli Pettinaroli can provide a complete range of connections end and nominal diameters in order to cover every customer request. Available connection ends are listed as follows:

- Male thread
- Female flat union end
- Female flat union end with nipple

Hoses can be selected among three nominal diameters: DN13, DN15, DN19 and DN25. Moreover, the customer can choose among several thickness of insulating expanded elastomeric pipes. Insulation pipes are available in several thickness: 6mm, 9mm, 13mm, 19mm, 25mm, 32mm.

For further information, please see the specific technical specification.



Component	Material
Internal pipe	EPDM
Twist	Stainless steel
Connections	BRASS CW614N (EN 12164)
O-Rings	EPDM

Characteristic	Male thread	Female flat union with nipple	Female flat union end
Pressure Rating	PN16	PN16	PN16
Temperature Range	5 – 90° C	5 – 90° C	5 – 90° C
Connection	1/2" – 3/4" – 1"	1/2" – 3/4"	1/2" – 3/4"
Nominal Diameter	DN13 – DN15 – DN19 - DN25	DN13 – DN15 – DN19 - DN25	DN13 – DN15 – DN19 - DN25
Length	20 – 200 cm	20 – 200 cm	20 – 200 cm
Tighten torque		35 Nm	35 Nm
Spanner		24mm (1/2") – 30mm (3/4")	24mm (1/2") – 30mm (3/4")

ACTUATION

Actuator selection

The table below shows actuator part numbers for different control types.

Type	Standard	Stroke	Adaptor
24 V, 0-10 V Proportional	VA7482	3,2 mm	0A7010
		6,3 mm	0A748X
24 V, 3 Point Floating	VA7481	3,2 mm	0A7010
		6,3 mm	0A748X
230 V, 3 Point floating	VA7481	3,2 mm	0A7010
		6,3 mm	0A748X
24 V, 0-10 V Proportional Thermic	A544P3	4 mm	VA64
24 V, ON-OFF Thermic	A544O2 or A544O4	4 mm	VA64
230 V, ON-OFF Thermic	A542O2 or A542O4	4 mm	VA64

Actuator fitting

Motorised actuators

To mount the actuator, first fully remove the black isolation cap. The actuator is supplied with a separate actuator mounting ring, this is mounted onto the valve headwork, if desired use a spot of thread locking adhesive to ensure the ring is retained with the valve. Making sure that the actuator is in its fully open position, mount the actuator on the headwork and then tighten the collar nut until it is hand tight.

Prior to removing the actuator it should be driven fully open before being powered down, this will ensure that it can be properly fitted again; do not try to fit an actuator with the spindle in an extended position.



Fitting motorised actuator to PICV

Thermic actuators – EVOPICV

To mount the actuator, first fully remove the black isolation cap. The actuator is supplied with a separate actuator mounting ring, this is mounted onto the valve headwork, if desired use a spot of thread locking adhesive to ensure the ring is retained with the valve. To mount the actuator it is then pushed onto the adapter ring until the clips retain the actuator.

Thermic actuators are supplied in a first open position, this means that they can be fitted easily. Once the actuators have been powered on, the actuator will be more difficult to fit unless driven open.



Fitting thermic actuator to PICV

Removing black protection handle

Do not attempt to fit the actuator if the black handle has not been fully removed. Sometimes the lower portion of the handle is too tight to remove by hand, in this case gently use a pair of grips to remove the handle.



Correct, handle fully removed



Incorrect, handle partially removed

Actuator details

0-10V Proportional (configurable)

This is our recommended actuator for both the EVOPICV 91 and 93 when fitted to forced convection terminal devices such as fan coils and air handing units. The actuator is a compact unit that is field configurable such that is suitable for a wide range of applications.

Control input

The actuator can be controlled by a number of different signals, including 0-10V, 2-10V, 0-5V, 5-10V and 4-20mA. The actuator is factory set to 0-10V.

Stroke direction

The stroke direction is factory set to direct acting, this may be changed in the field if required.

In order to suit the EVOPICV, the actuator should be set to reverse acting as the EVOPICV is normally open. This will allow the actuator to work with controllers that are set to direct acting without needing any change to the controls.

Stroke length

In order to adapt the stroke length to different valves, there is jumper that will change the effective stroke length. This jumper is factory set but can be changed on site if required. Please note that while the actuator will self calibrate to find the closing position, it works on a fixed stroke basis.

Calibration Cycle

When the power is applied, the actuator self-calibrates performing a complete cycle. The actuator moves the stem down for a complete mechanical valve stroke until no changes are detected. Once the auto-zero is detected the actuator moves the stem accordingly with the input signal.

Replaceable Cable

The connection cable is fitted with a plug so that the actuator can be swapped without unwiring the cable from the controller.



*3 Point motorised actuators
0-10V motorised actuator*

24v 3 Point motorised

This a 24v 3 point floating actuator for the EVOPICV 91 and 93, suitable fitted to forced convection terminal devices such as fan coils and air handing units. The actuator is a compact unit that is suitable for several sizes of valve. A 230v version is available for special applications.

Control input

The actuator is controlled on a drive open, drive closed basis.

When the signal is applied to the black and red wires, the actuator stem extends. When the signal is removed the actuator remains in position.

If the signal remains applied to the red wire, the actuator will time out and shut off the motor after approximately 90 seconds.

When the signal is applied to the black and orange wires, the actuator stem retracts. When the signal is removed the actuator remains in position.

If the signal remains applied to the orange wire, the actuator will time out and shut off the motor after approximately 90 seconds.

Controller Strategy

The actuator has a maximum stroke of 6mm making it suitable for a number of different valves in our range (both 91 and 93 EVOPICV), however there are a few things that need to be taken account of in the BMS controller strategy.

To ensure the best control characterisation it is vital to match drive time to the valve stroke so that there is no air gap between the actuator spindle and the valve spindle. The drive time should be calculated by multiplying the stroke length of the valve in mm by the time to drive 1mm.

All 3 point actuators need periodic re-synchronisation to account for positional drift, the re- synchronisation time should be set to 90 seconds in the closing direction of the valve.

24V or 230V Thermic On/Off

This actuator is suitable for passive terminal devices such as radiators and chilled beams, it is cost effective and operates silently. The 4 mm stroke actuator fits only EVOPICV 91 series while the 6 mm stroke is mounted on EVOPICV 93 series. The actuator mechanism uses a PTC resistor- heated elastic element and a compression spring. The wax element is heated by applying the operating voltage and moves the integrated ram. The force generated by the movement is transferred to the valve stem and thus opens and closes the valve. Fratelli Pettinaroli provides also a variation of 2 wires standard actuator: the 4 wires actuator, with additional microswitch, can be selected in order to have a supplementary control signal for a pump, a boiler, etc. The standard version the Normally Closed (NC) one but also the Normally Open (NO) one is available.

The actuator is nominally ON/OFF but can be controlled in a more modulating fashion by pulse pausing the controller output (Pulse Width Modulation). Our standard supply of these actuators is with fixed cable. If required, a premium version with 5 m long detachable cable is available.

First-open function

In its delivery condition, the actuator is normally open due to the First-Open function. This enables heating operation during the carcass construction phase even when the electric wiring of the single room control is not yet complete. When commissioning the system at a later date, the First-Open function is automatically unlocked by applying the operating voltage (for more than 6 minutes) and the actuator is fully operable.

Function indicator

The actuator has a function indicator in the form of a blue band on the actuator stem, this allows identifying the operating condition (actuator powered or not, corresponding to valve open or closed for Normally Closed actuator) at a glance.

Hysteresis

There is an inherent hysteresis in the operation of any thermic type actuator, when the actuator has not been used for a period of time there is an extra warm up period whilst the wax is heated up to its working temperature. When the voltage is removed from the actuator there is also cool down period before the actuator will begin to close due to the thermal mass of the wax.



*Thermic ON/OFF actuator
0-10V Thermic actuator*

0-10V Proportional thermic

The 0-10V proportional thermic actuator is offered as an alternative to the motorised proportional actuator. Our standard supply of these actuators is premium version with detachable cable and it is available with 4 or 6mm stroke.

Calibration

For the variant "normally closed", the valve is opened once by 0.5 mm and then closed again after applying the operating voltage of 24 V AC. For this, the first open function is unlocked and the valve closing point is detected. This ensures an optimum match with the specific valve used.

If a control voltage of 0.5 - 10 V DC is applied after the calibration process, the actuator opens the valve - after the dead time has elapsed with the piston movement, evenly and permanently corresponding to the valve travel. An internal optical path measurement controls the temperature required for the maximum stroke of 4 mm or 6 mm (minus over-elevation) and consequently the energy intake of the wax element. No excess energy is stored inside the wax element. If the control voltage is reduced, the electronic control system immediately adapts the heat input to the wax element. In the range of 0 - 0.5 V, the actuator remains in a quiescent state in order to ignore ripple voltage occurring in long cables. After the waiting time is elapsed, the valve is closed evenly with the closing force of the compression spring.

The closing force of the compression spring is matched to the opening force of commercially available valves and keeps the valve closed when de-energised (NC).

Stand-by operation

The wax element is maintained at stand-by temperature 20 minutes after the control voltage has dropped below 0.5V

First-Open Function

In its delivery condition, the actuator is normally open due to the First-Open function. This enables heating operation during the carcass construction phase even when the electric wiring of the single room control is not yet complete. When commissioning the system at a later date, the First-Open function is automatically unlocked by applying the operating voltage (for more than 6 minutes) and the actuator is fully operable.

Function Indicator

The actuator has a function indicator in the form of a blue band on the actuator stem, this allows identifying the operating condition (valve open or closed) at a glance.

Hysteresis

There is an inherent hysteresis in the operation of any thermic type actuator, when the actuator has not been used for a period of time there is an extra warm up period whilst the wax is heated up to its working temperature. When the voltage is removed from the actuator there is also cool down period before the actuator will begin to close due to the thermal mass of the wax.

PETTINAROLI GROUP



Jomar Group
Warren - USA

Hydronic Components HCI
Warren - USA



Pettinaroli Denmark
Midelfart - DEN

Pettinaroli UK
Birmingham - UK

TSM Galvanocromo
Gozzano - ITA

FRATELLI PETTINAROLI
S.Maurizio d'Opaglio - ITA

Pettinaroli Suisse
Montreux - SUI

Pettinaroli France
Carmaux - FRA



Pettinaroli Middle East
Dubai - UAE

Making **your work** every day **easier**

TOZEN

Tozen Industrial Co.,Ltd
3388/62 Sirinrat Building,Rama IV Road
Klongton, Klongtoey, Bangkok 10110
Tel: 02-0290100 Fax: 02-029-0111
E-Mail: sales@tt.tozen.com www.tozen.co.th

 **FRATELLI
PETTINAROLI** s.p.a
CLIMATE SYSTEMS TECHNOLOGY

Via Pianelli, 38
28017 San Maurizio d'Opaglio (NO) ITALY
Tel. +39 0322 96217 - Fax. +39 0322 96546
www.pettinaroli.com - info@pettinaroli.com