

Rev.	ECN No.	Revision note.	Date	Revised by
------	---------	----------------	------	------------

Tolerance on overall length(OAL).				
OAL	Nominal size	up to 100A	125A to 400A	450A to 1000A
	up to 500	±3	±4	±6
501 to 1000		±4	±5	±8
Refer. DIN EN 14917:2012-06				

FLANGE TYPE		
TYPE OF FLANGE	FF	RF
STANDARD FLANGE	●	●
JIS 5K	●	
JIS 10K	●	
JIS 20K		●
PN 10	●	
PN 16		●
PN 25		●
ANSI150		●
ANSI300		●

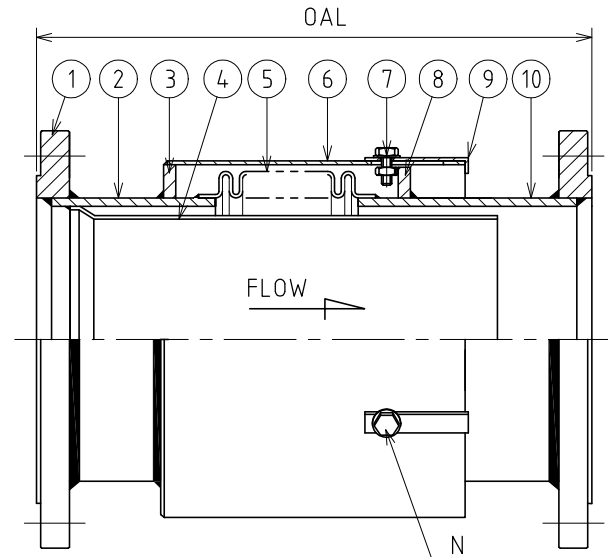
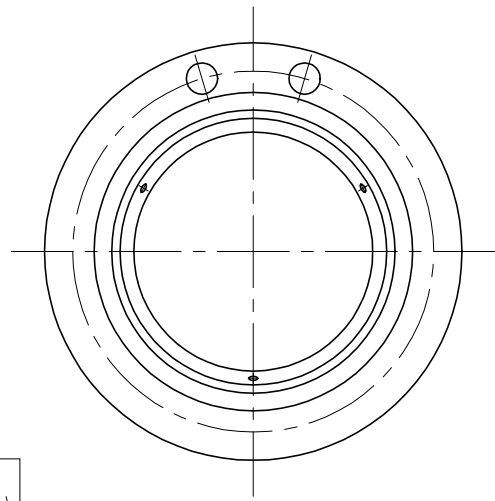

No.	SIZE mm(inch)	OAL (mm)	DESIGN PRESSURE (bar)	DESIGN TEMP (Deg C)	AXIAL MOVEMENT(mm.)	N (Set)
1	40A(1.1/2")	365	10	250	25	2
2	50A(2")	365	10	250	25	2
3	65A(2.1/2")	415	10	250	35	2
4	80A(3")	415	10	250	35	2
5	100A(4")	415	10	250	35	3
6	125A(5")	440	10	250	35	3
7	150A(6")	440	10	250	35	3
8	200A(8")	440	10	250	35	4
9	250A(10")	465	10	250	35	4
10	300A(12")	465	10	250	35	4
11	350A(14")	465	10	250	35	4
12	400A(16")	490	10	250	35	4
13	450A(18")	490	10	250	35	4
14	500A(20")	490	10	250	35	4
15	600A(24")	520	10	250	35	4

Item	Part Name	Material	Q'ty	Remark
10	SHORT PIPE 2	CS/SUS304/SUS316	1	
9	CLAMP PLATE	SS400/SUS304	N	REMOVE AFTER INSTALLATION
8	RING 2	SS400/SUS304	1	
7	SHIPPING BOLT, NUT, WASHER	SS400/SUS304	N	
6	COVER	SS400/SUS304	1	
5	STAINLESS STEEL BELLOW	SUS304/SUS316L	1	
4	INNER SLEEVE	SUS304/SUS316L	1	WITH DRAIN HOLES
3	RING 1	SS400/SUS304	1	
2	SHORT PIPE 1	CS/SUS304/SUS316	1	
1	FIXED FLANGE	SS400/SUS304/SUS316	2	JIS10K, ANSI150, PN10



Wellgrow Industrial Estate  
Chachoengsao, Thailand  
www.tozen.co.th

PROPRIETARY DATA

THIS DOCUMENT CONTAINS TOZEN INDUSTRIAL CO.,LTD.  
CONFIDENTIAL AND PROPRIETARY INFORMATION AND CANNOT  
BE USED, DUPLICATED OR DISCLOSED IN WHOLE OR IN PART  
EXCEPT WITH EXPRESS WRITTEN PERMISSION OF  
TOZEN INDUSTRIAL CO.,LTD.

Note : - Holes on flange may not shown the number in fact.  
- Any information provided in drawing is subject to change without notice for error rectification or design modification.

DATE	DRAWN BY	CHECKED BY	APPROVED BY	TITLE	EXPANSION JOINT,SJT-2100	Revision	Size
	20/11/2017	PRATUENG T.	WUTHIPAN	SOMKRITSADA	DWG NO. MTE-18-011-00	00	A4
	MATERIAL	See in Table	SCALE : N.T.S	UNIT : mm	Method		