

# Flexible Duct

JABARA TYPE FABRIC EXPANSION JOINT

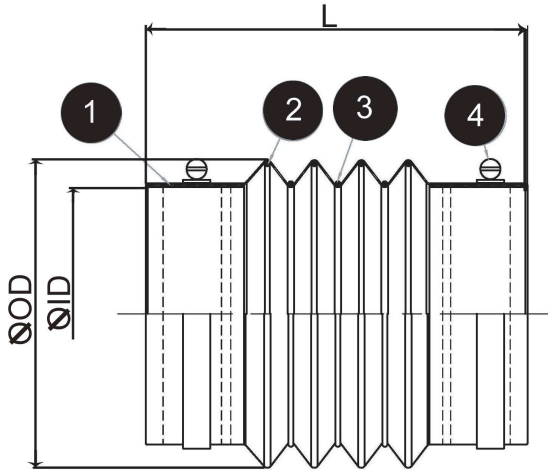

**MATERIAL TABLE:**

Item	Part Name	Material
1	Fabric	SILICONE FABRIC
2	Inner ring	SUS304
3	Outer ring	SUS304
4	Clamp	SUS304

<b>Max. Working Temperature :</b>	249°C
<b>Max. Working Pressure:</b>	0.5 kg/cm <sup>2</sup>
<b>Application :</b>	Exhaust air, Ambient air

- Please consult us for available material or application.
- All dimensions are for standard reference which can be adjusted to actual requirement.
- Greater movements are obtained with more convolutions which are designed according to actual requirement.

**● SPECIFICATION**

Size	ID	OD	L	Allowable movement			Number of Clamp
				Axial Compression	Axial Elongation	Lateral Movement	
50A	62	73	140	20	4	5	2
65A	75	88	150	25	4	5	2
80A	91	107	160	30	5	5	2
100A	116	137	180	40	6	10	2
125A	143	169	200	50	8	10	2
150A	170	201	220	60	9	10	2
200A	221	261	250	80	12	15	4
250A	276	235	290	100	15	15	4
300A	327	385	290	100	15	15	4
350A	359	423	310	100	15	15	4
400A	409	483	380	150	23	20	4
450A	460	543	415	150	23	20	4
500A	511	603	400	150	23	20	4
550A	563	664	485	200	30	25	4
600A	614	724	520	200	30	25	4
650A	664	784	520	200	30	25	4
700A	715	844	520	200	30	25	4

**TOZEN INDUSTRIAL CO., LTD.**  
 3388/62 18TH FLOOR, SIRINRAT BLDG.,  
 RAMA IV RD., BANGKOK 10110 THAILAND  
 TEL : (66) 0-2029-0100  
 FAX : (66) 0-2029-0111  
 E-MAIL : sales@tt.tozen.com  
 URL : www.tozen.co.th

**TOZEN CORPORATION**  
 8-4, ASAHI YOSHIKAWA  
 SAITAMA 342-008 JAPAN  
 TEL : 048-993-1030  
 FAX : 048-993-1038