



TVS/TVR

Stainless Steel Vertical Multistage Pump



TOZEN INDUSTRIAL CO., LTD.

3388/62 18th Fl., Sirinrat Bldg., Rama IV Rd., Klongtoey, Bangkok 10110 Thailand

Tel : 0-2029-0100 Fax : 0-2029-01

E-mail : sales@tt.tozen.com URL : www.tozen.co.th

Factory : Wellgrow Industrial Estate, 126 Moo 9, Bangwao, Bangpakong, Chachoengsao 24180 Thailand



Application

- Suitable for transferring liquids of low viscosity, non-inflammable and non-explosive, not containing solid particles or fibers
- Water supply & drainage for high-rise buildings, filtration and transfer at waterworks, pressure boosting in main pipe
- Washing and cleaning systems, boiler feeding, cooling water circulation, water treatment systems, auxiliary system, support equipment
- Ultra-filtration systems, reverse-osmosis systems, distillation systems, separators, swimming pools
- Agricultural irrigation: sprinkler irrigation, drip-feed irrigation
- Food & beverage industry
- Fire-fighting system

Operating Conditions

- Low viscosity, non-inflammable and non-explosive liquids not containing solid particles or fibers. The liquids must not chemically attack the pump materials. When pumping liquids with a density or viscosity is higher than that of water, a motor with a higher output power rating shall be used.
- Liquid temperature: -20°C ~ +120°C
- Flow ranges: 0.7-240 m³/h
- Liquid pH value: 4 - 10
- Max. ambient temperature: +40°C
- Max. operation pressure: 33 bar
- Altitude: up to 1000 m

Motor

- IE 2 motor (IE 3 motor optional)
- Totally enclosed & fan-cooled
- Protection class: IP55
- Standard voltage: 50Hz 1 x 220V/3 x 380V

Identification Codes

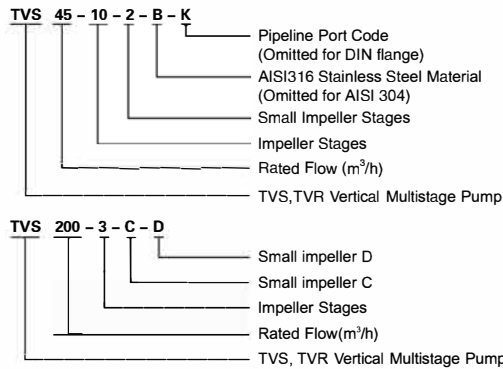

TVS: Stainless steel wetted parts
TVR: Cast iron base & pump cover

Identifications codes of flange structure
A: Oval flange; K: Clamp connector;
C: Threaded connector

Ambient Temperature

Max. ambient temperature: +40°C. Ambient temperature above 40°C or installation at altitude of more than 1000 meters above sea level require the use of an oversize motor. Because of low air density and poor cooling effects, the motor output power P₂ will be decreased. See the picture.

In such cases, it may be necessary to use a motor with a higher output power rating.

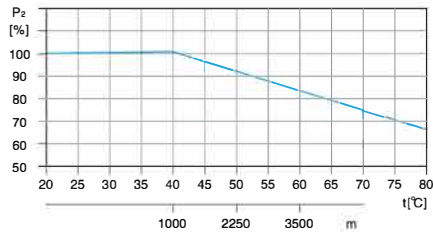

For example, when the pump is installed at altitude of more than 3500 meters above sea level, P₂ will be decreased to 88%. When the ambient temperature is 70°C, P₂ will be decreased to 78%.

Minimum Inlet Pressure-Npsh

Calculation of the inlet pressure "H" is recommended in these situations:

- The liquid temperature is high.
- The flow is significantly higher than the rated flow.
- Water is drawn from depths.
- Inlet conditions are poor.

To avoid cavitation, make sure that there is a minimum pressure on the suction side of the pump. The maximum suction lift "H" in meters head can be calculated as follows:

$$H = P_b \times 10.2 - NPSH - H_f - H_v - H_s$$

P_b = Barometric pressure in bar. (Barometric pressure can be set to 1 bar). In closed systems, P_b indicates the system pressure in bar.

NPSH = Net Positive Suction Head in meters head. (To be read from the NPSH curve at the highest flow the pump will be delivering.)

H_f = Friction loss in suction pipe in meters head. (At the highest flow the pump will be delivering.)

H_v = Vapor pressure in meters head. (To be read from the vapor pressure scale. "H_v" depends on the liquid temperature "t_m")

H_s = Safety margin=minimum 0.5 meters head.

If the "H" calculated is positive, the pump can operate at a suction lift of maximum "H" meters head.

If the "H" calculated is negative, an inlet pressure of minimum "H" meters head is required.

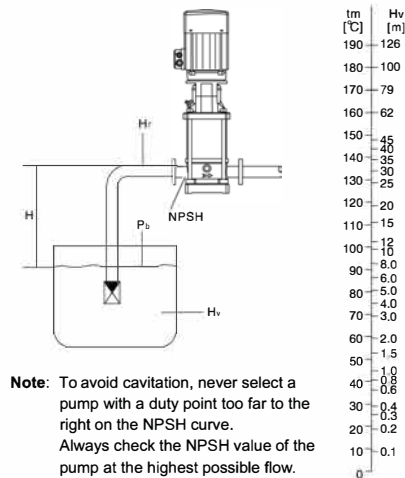

Note: To avoid cavitation, never select a pump with a duty point too far to the right on the NPSH curve. Always check the NPSH value of the pump at the highest possible flow.

Maximum Inlet Pressure

The following table shows the maximum permissible inlet pressure. However, the current inlet pressure + the pressure against a closed valve must always be lower than the Max. permissible operating pressure.

If the maximum permissible operating pressure is exceeded, the bearing in the motor may be damaged and the life of the shaft seal reduced.

Model	Maximum Inlet Pressure [bar]
TVR1, TVS1	
1-2 — 1-36	10
TVR2, TVS2	
2-2 — 2-12	6
2-3 — 2-26	10
2-13 — 2-26	15
TVR3, TVS3	
3-2 — 3-29	10
3-31 — 3-36	15
TVR4, TVS4	
4-2 — 4-11	6
4-3 — 4-22	10
4-12 — 4-22	15
TVR5, TVS5	
5-2 — 5-16	10
5-18 — 5-29	15
TVR10, TVS10	
10-1 — 10-6	8
10-7 — 10-22	10
TVR15, TVS15	
15-1 — 15-3	8
15-4 — 15-17	10
TVR20, TVS20	
20-1 — 20-3	8
20-4 — 20-17	10
TVR32, TVS32	
32-1-1 — 32-4	4
32-5-2 — 32-10	10
32-11 — 32-14	15
TVR45, TVS45	
45-1-1 — 45-2	4
45-3-2 — 45-5	10
45-6-2 — 45-13-2	15
TVR64, TVS64	
64-1-1 — 64-2-2	4
64-2-1 — 64-4-2	10
64-4-1 — 64-8-1	15
TVR90, TVS90	
90-1-1 — 90-1	4
90-2-2 — 90-3-2	10
90-3 — 90-6	15
TVR120, TVS120	
120-1 — 120-2-1	10
120-2 — 120-5-1	15
120-5 — 120-7	20
TVR150, TVS150	
150-1-1 — 150-2-2	10
150-2-1 — 150-4-1	15
150-4 — 150-6	20
TVR200, TVS200	
200-1-D — 200-2-2C	10
200-1-C — 200-2-2C	15
200-2-C — 200-4	20

How to Read The Curve Charts

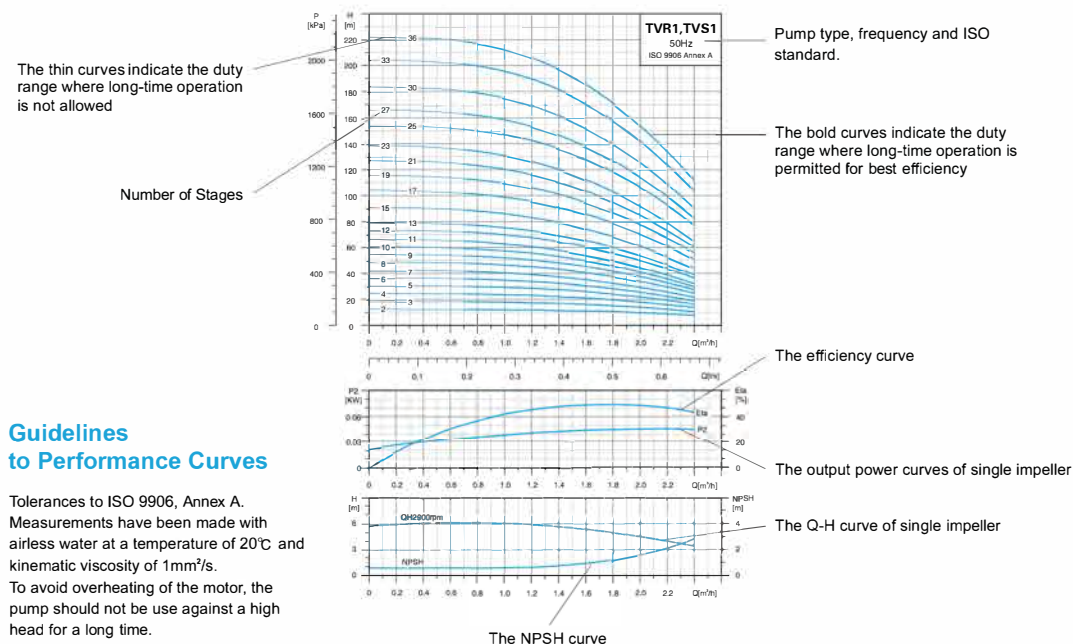

Guidelines to Performance Curves

Tolerances to ISO 9906, Annex A. Measurements have been made with airless water at a temperature of 20°C and kinematic viscosity of 1mm²/s. To avoid overheating of the motor, the pump should not be use against a high head for a long time.

Minimum Flow Rate

Due to the risk of overheating, the pump should not be used at a flow below the minimum flow rate. The curve below shows the minimum flow rate as a percentage of the nominal flow rate in relation to the liquid temperature.

Air cooling apparatus

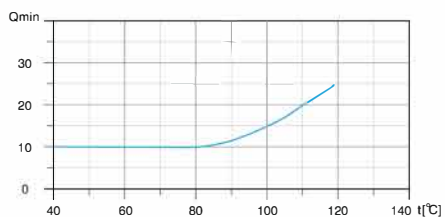

Note: The outlet valve must be opened when the pump is in operation.

Terminal Box Positions

(Note: set to position 1 before delivery)

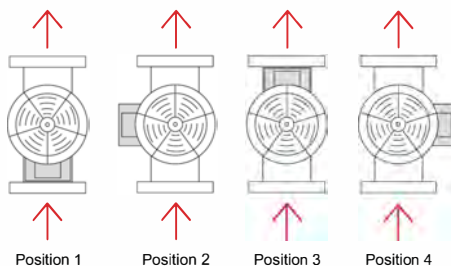

Product Range

MODEL	TVR(S)1	TVR(S)2	TVR(S)3	TVR(S)4	TVR(S)5	TVR(S)10	TVR(S)15	TVR(S)20	TVR(S)32	TVR(S)45	TVR(S)64	TVR(S)90	TVR(S)120	TVR(S)150	TVR(S)200
DESCRIPTION															
Rated flow [m ³ /h]	1	2	3	4	5	10	15	20	32	45	64	90	120	150	200
Flow range [m ³ /h]	0.7-2.4	1.0-3.5	1.2-4.5	1.5-8	2.5-8.5	5-13	8-23	10.5-29	15-40	22-58	30-85	45-120	60-150	80-180	100-240
Max. pressure [bar]	22	23	24	21	24	22	23	25	28	33	22	20	16	16	16
Motor power [kW]	0.37-2.2	0.37-3	0.37-3	0.37-4	0.37-4	1.1-7.5	1.1-15	1.1-18.5	1.5-30	3-45	4-45	5.5-4.5	11-75	11-75	18.5-110
Temperature Range [°C]	-20°C~+120°C (Note: Both the Max. permissible pressure and liquid temperature range refer to the pump capacity.)														
Max. pump efficiency [%]	45	46	55	59	60	65	70	72	78	79	80	81	74	73	79
Pipe connection-TVRR															
Oval flange	G1	G1	G1	G1 1/4	G1 1/4	-	-	-	-	-	-	-	-	-	-
DIN flange	DN25	DN25	DN25	DN32	DN32	DN40	DN50	DN50	DN65	DN80	DN100	DN100	DN125	DN125	DN150
Flange structure	○	○	○	○	○	○	○	○	●	●	●	●	●	●	●
Pipe connection-TVS															
Oval flange	-	-	-	-	-	-	-	-	-	-	-	-	-	-	-
DIN flange	DN32	DN32	DN32	DN32	DN32	DN40	DN50	DN50	DN65	DN80	DN100	DN100	DN125	DN125	DN150
Flange structure	●	●	●	●	●	●	●	●	●	●	●	●	●	●	●
Clamp connector	Φ42	Φ42	Φ42	Φ42	Φ42	-	-	-	-	-	-	-	-	-	-
Threaded connector	G1 1/4	G1 1/4	G1 1/4	G1 1/4	G1 1/4	-	-	-	-	-	-	-	-	-	-

Note: ○ It means stationary flange structure, ● It means dynamic flange structure.

Scope of Performance-TVRR, TVS

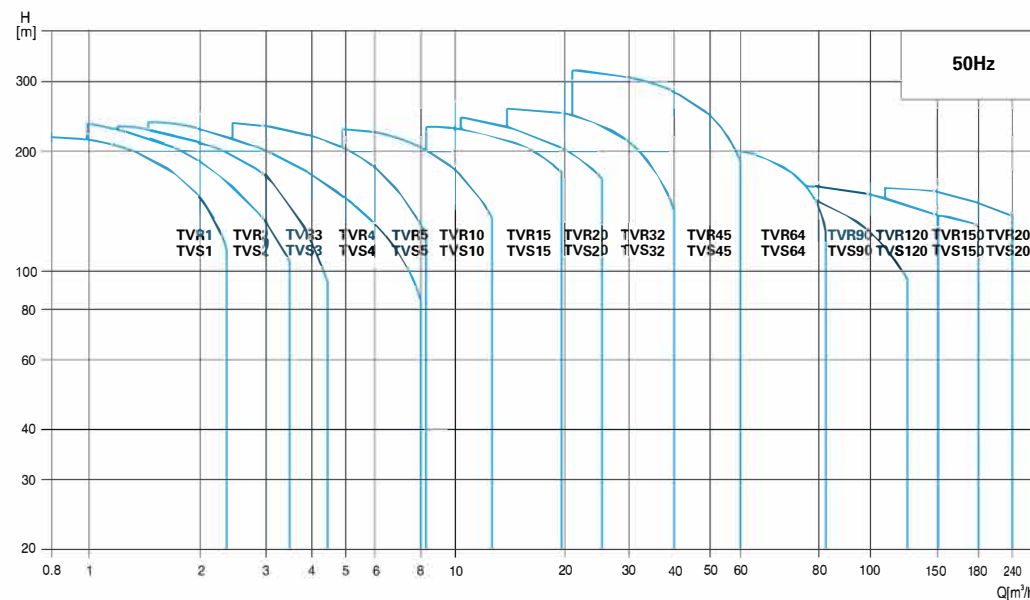

Cross Section

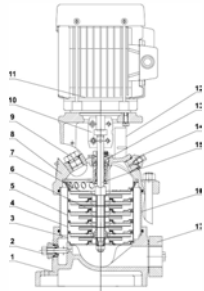

MODEL: TVR1 (2.3.4.5)

Part	Material
1 Base	HT200
2 Drainage plug assembly	AISI304
3 Primary diffuser	AISI304
4 Diffuser with bearing	AISI304
5 Medium diffuser	AISI304
6 Impeller	AISI304
7 Final volute	AISI304
8 Motor base	HT200
9 Filling plug	AISI304
10 Coupling	Iron based powder metallurgy
11 Motor	
12 Guarding plate	AISI304
13 Cartridge seal	
14 Vent plug assembly	AISI304
15 Pump shaft	AISI304
16 Pump barrel	AISI304
17 Oval flange	HT200

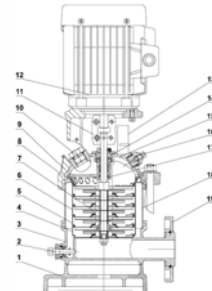

MODEL: TVS1 (2.3.4.5)

Part	Material	Optional Material
1 Base plate	HT200	
2 Drainage plug assembly	AISI304	AISI316
3 Chasis	ZG304	ZG316
4 Primary diffuser	AISI304	AISI316
5 Diffuser with bearing	AISI304	AISI316
6 Medium diffuser	AISI304	AISI316
7 Impeller	AISI304	AISI316
8 Final volute	AISI304	AISI316
9 Motor base	HT200	
10 Filling plug	AISI304	AISI316
11 Coupling	Iron based powder metallurgy	
12 Motor		
13 Guarding plate	AISI304	
14 Cartridge seal		
15 Pump cover	ZG304	ZG316
16 Vent plug assembly	AISI304	AISI316
17 Pump shaft	AISI304	AISI316
18 Pump barrel	AISI304	AISI316
19 Flange	ZG35	

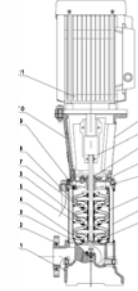

MODEL: TVR32 (45.64.90)

Part	Material
1 Base plate	HT200
2 Flange	ZG35
3 Primary diffuser	AISI304
4 Medium diffuser	AISI304
5 Diffuser with bearing	AISI304
6 Impeller	AISI304
7 Shaft sleeve assembly	
8 Final diffuser	AISI304
9 Vent plug assembly	AISI304
10 Motor base	HT200
11 Motor	
12 Guarding plate	AISI304
13 Coupling	QT400
14 Cartridge seal	
15 HT200 Pump head	HT200
16 Filling plug	AISI304
17 Tension plate	AISI304
18 Pump barrel	AISI304
19 Pump shaft	AISI304

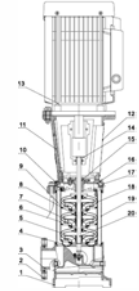

MODEL: TVS32 (45.64.90)

Part	Material	Optional Material
1 Base plate	HT200	
2 Flange	ZG35	
3 Chasis	ZG304	ZG316
4 Primary diffuser	AISI304	AISI316
5 Medium diffuser	AISI304	AISI316
6 Diffuser with bearing	AISI304	AISI316
7 Impeller	AISI304	AISI316
8 Shaft sleeve assembly		
9 Final diffuser	AISI304	AISI316
10 Vent plug assembly	AISI304	AISI316
11 Motor base	HT200	
12 Motor		
13 Guarding plate	AISI304	
14 Coupling	QT400	
15 Cartridge seal		
16 Pump head	ZG304	ZG316
17 Filling plug	AISI304	AISI316
18 Tension plate	AISI304	AISI316
19 Pump barrel	AISI304	AISI316
20 Pump shaft	AISI304	AISI316

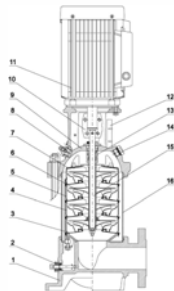

MODEL: TVR10 (15.20)

Part	Material
1 Base	HT200
2 Drainage plug assembly	AISI304
3 Primary diffuser	AISI304
4 Diffuser with bearing	AISI304
5 Medium diffuser	AISI304
6 Impeller	AISI304
7 Final volute	AISI304
8 Filling plug	AISI304
9 Motor base	HT200
10 Coupling	Iron based powder metallurgy
11 Motor	
12 Guarding plate	AISI304
13 Cartridge seal	
14 Vent plug assembly	AISI304
15 Pump shaft	AISI304
16 Pump barrel	AISI304

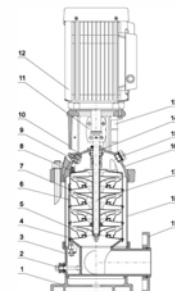

MODEL: TVS10 (15.20)

Part	Material	Optional Material
1 Base plate	HT200	
2 Drainage plug assembly	AISI304	AISI316
3 Chasis	ZG304	ZG316
4 Primary diffuser	AISI304	AISI316
5 Diffuser with bearing	AISI304	AISI316
6 Medium diffuser	AISI304	AISI316
7 Impeller	AISI304	AISI316
8 Final volute	AISI304	AISI316
9 Filling plug	AISI304	AISI316
10 Motor base	HT200	
11 Coupling	Iron based powder metallurgy	
12 Motor		
13 Guarding plate	AISI304	
14 Cartridge seal		
15 Vent plug assembly	AISI304	AISI316
16 Pump cover	ZG304	AISI316
17 Pump shaft	AISI304	AISI316
18 Pump barrel	AISI304	AISI316

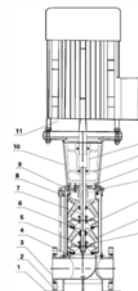

MODEL: TVR120 (150.200)

Part	Material
1 Base plate	HT200
2 Flange	ZG35
3 Base	HT200
4 Primary diffuser	AISI304
5 Medium diffuser	AISI304
6 Diffuser with bearing	AISI304
7 Impeller	AISI304
8 Final diffuser	AISI304
9 Pump head	HT200
10 Motor base	HT200
11 Motor	
12 Coupling	QT400
13 Guarding plate	AISI304
14 Cartridge seal	
15 Filling plug	AISI304
16 Tension plate	AISI304
17 Pump barrel	AISI304
18 Pump shaft	AISI304

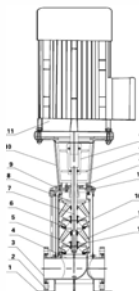

MODEL: TVS120 (150.200)

Part	Material	Optional Material
1 Base plate	HT200	
2 Flange	ZG35	
3 Chasis	ZG304	ZG316
4 Primary diffuser	AISI304	AISI316
5 Medium diffuser	AISI304	AISI316
6 Diffuser with bearing	AISI304	AISI316
7 Impeller	AISI304	AISI316
8 Final diffuser	AISI304	AISI316
9 Pump head	ZG304	ZG316
10 Motor base	HT200	
11 Motor		
12 Coupling	QT400	
13 Guarding plate	AISI304	
14 Cartridge seal		
15 Filling plug	AISI304	AISI316
16 Tension plate	AISI304	AISI316
17 Pump barrel	AISI304	AISI316
18 Pump shaft	AISI304	AISI316

Hydraulic Performance Curves

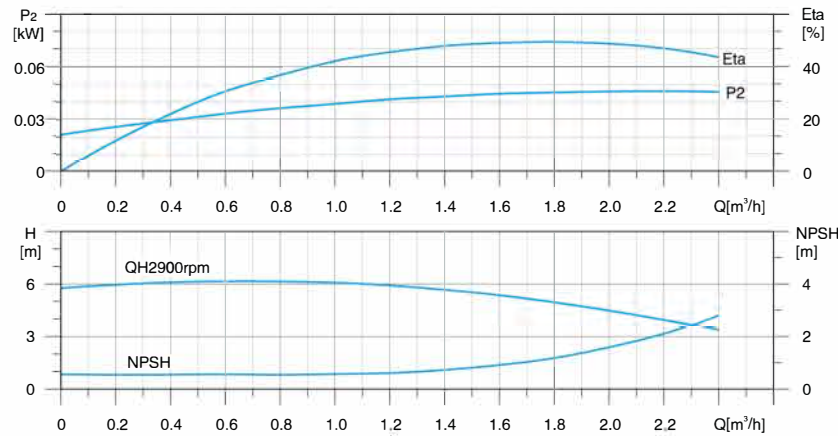
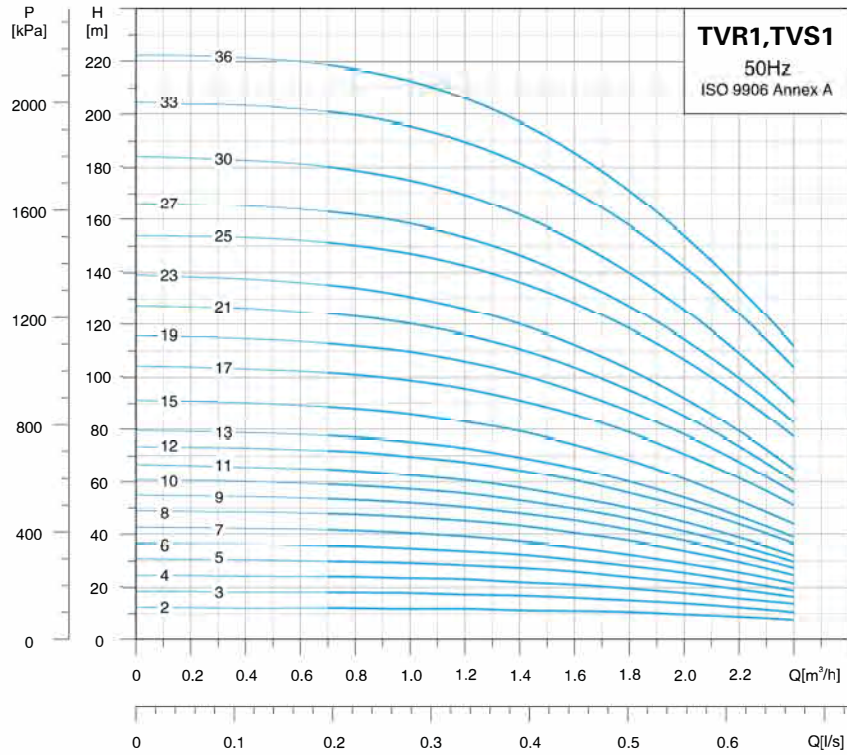

Dimension Drawing

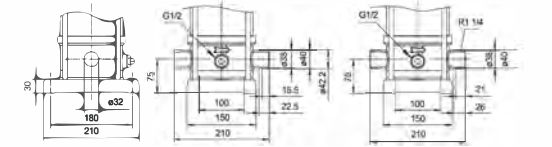
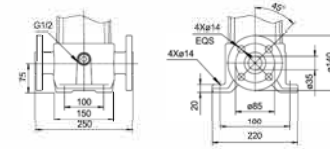
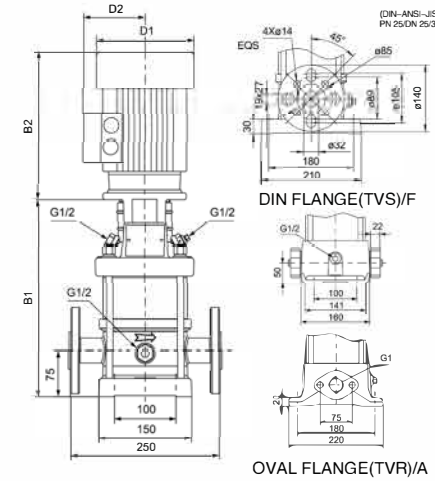

MODEL	OVAL FLANGE (TVR)		DIN FLANGE (TVS)		D1	D2
	B1	B1+B2	B1	B1+B2		
1-2	238	468	264	494	136	109
1-3	256	486	282	512	136	109
1-4	274	504	300	530	136	109
1-5	292	522	318	548	136	109
1-6	310	540	336	566	136	109
1-7	328	558	354	584	136	109
1-8	346	576	372	602	136	109
1-9	364	594	390	620	136	109
1-10	382	612	408	638	136	109
1-11	400	630	426	656	136	109
1-12	422	672	448	698	155	124
1-13	440	690	466	716	155	124
1-15	476	726	502	752	155	124
1-17	512	762	538	788	155	124
1-19	548	798	574	824	155	124
1-21	584	834	610	860	155	124
1-23	620	870	646	896	155	124
1-25	672	982	698	1008	175	137
1-27	708	1018	734	1044	175	137
1-30	762	1072	788	1098	175	137
1-33	816	1126	842	1152	175	137
1-36	870	1180	896	1206	175	137

Note: B1 and B1+B2 of clamp connector and threaded connector are in compliance with that of DIN flange.

MODEL	POWER [kW]	Q [m ³ /h]	0.4	0.6	0.8	1.0	1.2	1.4	1.6	1.8	2.0
1-2	0.37	12	12	12	12	12	12	11	11	10	10
1-3	0.37	18	18	18	18	18	17	17	16	15	14
1-4	0.37	24	24	24	24	24	22	22	21	19	18
1-5	0.37	30	30	30	30	29.5	28	27	26	24	22
1-6	0.37	36	36	35	35	34	32	30	28	25	25
1-7	0.37	42	42	41	40.5	39	37	35	32	30	30
1-8	0.55	48	48	47	46.5	45	43	40	38	34	34
1-9	0.55	54	54	53	52	50	48	45	42	37	37
1-10	0.55	60	59	58	57.5	55	53	50	46	41	41
1-11	0.55	65	65	64	63	61	58	54	51	45	45
1-12	0.75	73	72	71	70	67	64	61	56	50	50
1-13	0.75	78	78	77	75	73	69	65	60	54	54
1-15	0.75	90	90	88	86	83	79	74	68	61	61
1-17	1.1	103	102	101	98	95	91	85	78	70	70
1-19	1.1	115	114	112	110	106	101	94	87	78	78
1-21	1.1	126	125	123	120	116	110	103	95	85	85
1-23	1.1	137	136	134	130	126	120	112	103	92	92
1-25	1.5	153	152	150	145	142	136	128	119	106	106
1-27	1.5	165	164	162	157	153	146	137	128	114	114
1-30	1.5	182	181	178	173	169	162	152	140	126	126
1-33	2.2	203	202	199	194	189	181	170	158	142	142
1-36	2.2	221	220	217	210	206	197	185	170	154	154

Hydraulic Performance Curves

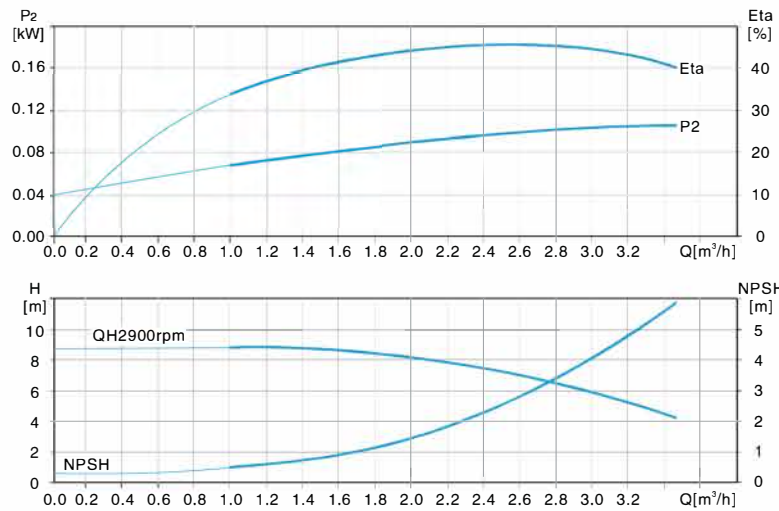
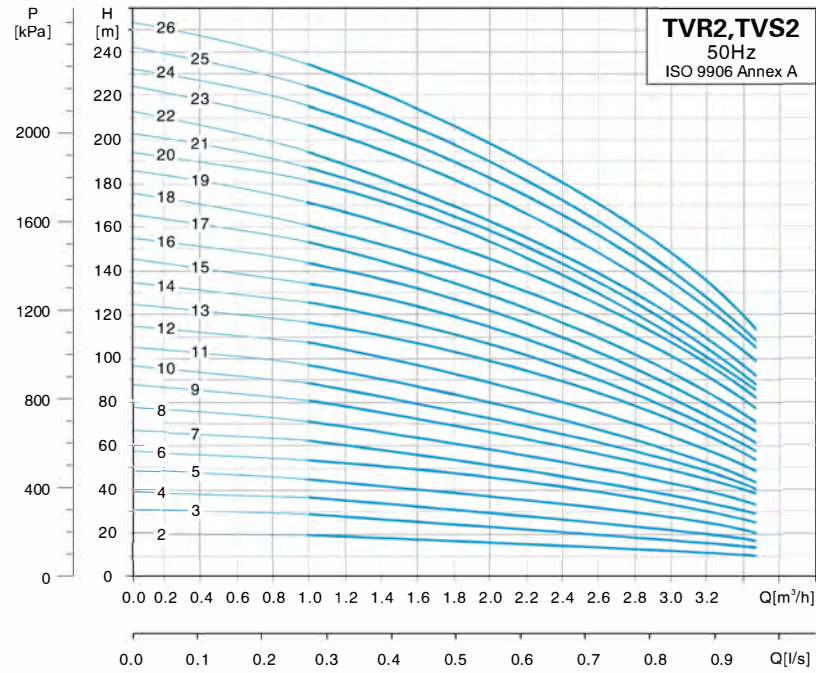

Dimension Drawing

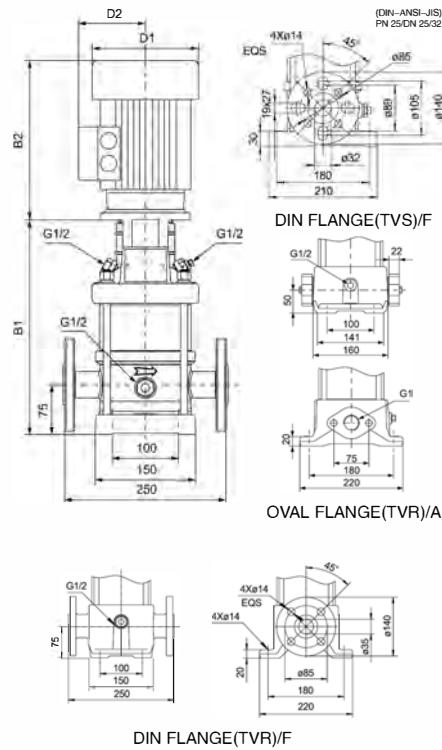

MODEL	OVAL FLANGE(TVR)		DIN FLANGE(TVS)		D1	D2
	B1	B1+B2	B1	B1+B2		
2-2	220	440	245	465	140	110
2-3	238	458	263	483	140	110
2-4	256	476	281	501	140	110
2-5	274	494	299	519	140	110
2-6	297	547	322	572	160	125
2-7	315	565	340	590	160	125
2-8	333	583	358	608	160	125
2-9	351	601	376	626	160	125
2-10	369	619	394	644	160	125
2-11	387	637	412	662	160	125
2-12	422	712	447	737	180	125
2-13	440	730	465	755	180	125
2-14	458	748	483	773	180	125
2-15	476	766	501	791	180	125
2-16	494	784	519	809	180	125
2-17	512	802	537	827	180	125
2-18	530	820	555	845	180	125
2-19	548	838	573	863	180	125
2-20	566	856	591	881	180	125
2-21	584	874	609	899	180	125
2-22	602	892	627	917	180	125
2-23	628	958	653	983	190	140
2-24	646	976	671	1001	190	140
2-25	664	994	689	1019	190	140
2-26	682	1012	707	1037	190	140

Note: B1 and B1+B2 of clamp connector and threaded connector are in compliance with that of DIN flange.

MODEL	POWER[kW]	Q[m³/h]	H(m)									
			1.0	1.2	1.6	2.0	2.5	2.8	3.2	3.5		
2-2	0.37	18	17	16	15.5	13.5	12	10	8			
2-3	0.37	27	26	24	22.5	19.5	18	15	12			
2-4	0.55	36	35	33	30.5	27	24	17	16			
2-5	0.55	45	43	40	37	32.5	30	24	20			
2-6	0.75	53	52	50	45.5	40	36	30	24			
2-7	0.75	63	61	57	52	45.5	41	35	28			
2-8	1.1	71	69	65	59	51	47	40	33			
2-9	1.1	80	78	73	68.5	60	54	45	37			
2-10	1.1	89	86	81	74	65	59	49	40			
2-11	1.1	98	95	89	82	71.5	64	54	44			
2-12	1.5	107	103	97	90	78	71	59	47			
2-13	1.5	116	114	106	98	86.5	78	65	52			
2-14	1.5	125	122	114	105	92	84	69	57			
2-15	1.5	134	130	123	112	98	90	73	60			
2-16	2.2	143	139	131	120	104	96	79	66			
2-17	2.2	152	148	139	128	111	102	85	70			
2-18	2.2	161	157	148	136	122	108	91	76			
2-19	2.2	170	165	156	143	128	113	95	81			
2-20	2.2	179	174	164	150	134	119	100	85			
2-21	2.2	188	183	172	157	140	124	105	88			
2-22	2.2	197	192	180	165	145	130	110	90			
2-23	3.0	205	201	188	173	153	137	105	97			
2-24	3.0	214	210	197	181	160	144	120	105			
2-25	3.0	223	219	205	189	168	151	125	107			
2-26	3.0	232	228	214	198	176	158	130	110			

Hydraulic Performance Curves

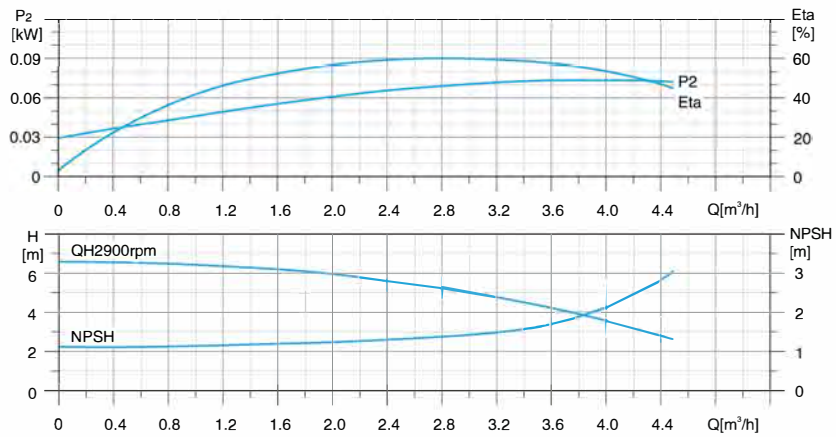
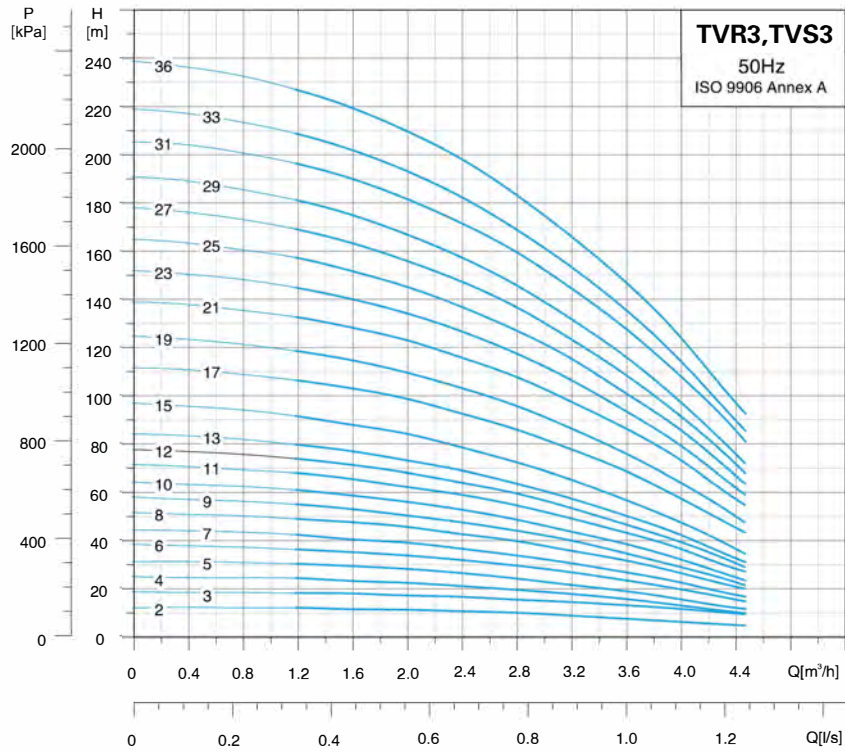

Dimension Drawing

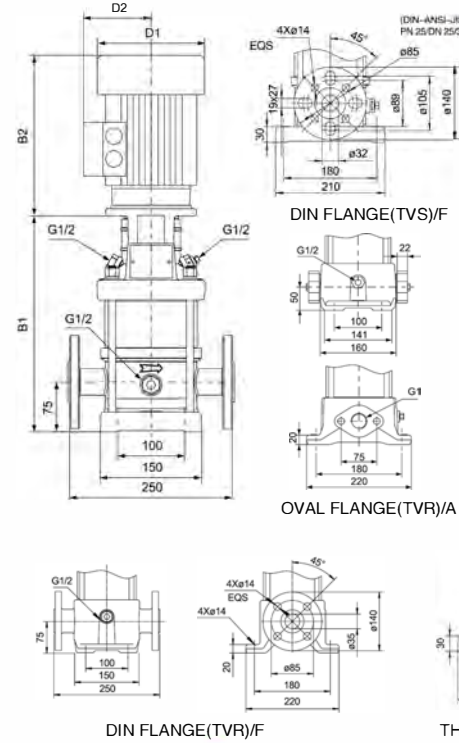

MODEL	OVAL FLANGE(TVR)		DIN FLANGE(TVS)		D1	D2
	B1	B1+B2	B1	B1+B2		
3-2	238	468	264	494	136	109
3-3	256	486	282	512	136	109
3-4	274	504	300	530	136	109
3-5	292	522	318	548	136	109
3-6	310	540	336	566	136	109
3-7	328	558	354	584	136	109
3-8	350	600	376	626	155	124
3-9	368	618	394	644	155	124
3-10	386	636	412	662	155	124
3-11	404	654	430	680	155	124
3-12	422	672	448	698	155	124
3-13	440	690	466	716	155	124
3-15	476	726	502	752	155	124
3-17	528	838	554	864	175	137
3-19	564	874	590	900	175	137
3-21	600	910	626	936	175	137
3-23	636	946	662	972	175	137
3-25	672	982	698	1008	175	137
3-27	708	1018	734	1044	175	137
3-29	744	1054	770	1080	175	137
3-31	784	1114	810	1140	195	151
3-33	820	1150	846	1176	195	151
3-36	874	1204	900	1230	195	151

Note: B1 and B1+B2 of clamp connector and threaded connector are in compliance with that of DIN flange.

MODEL	POWER[kW]	Q[m³/h]	H(m)							
			1.2	1.6	2.0	2.4	2.8	3.2	3.6	4.0
3-2	0.37		13	12	12	11	11	10	8	7.5
3-3	0.37		19	19	18	17	16	15	14	12
3-4	0.37		25	24	23	22	20	19	17	14
3-5	0.37		31	31	29	27	25	24	20	17
3-6	0.55		37	36	35	33	30	28	24	21
3-7	0.55		43	40	40	37	35	32	28	24
3-8	0.75		51	48	47	44	41	38	33	28
3-9	0.75		56	54	51	48	45	42	36	30
3-10	0.75		62	60	57	54	50	46	40	33
3-11	1.1		69	66	63	60	56	51	44	38
3-12	1.1		75	72	69	65	61	56	48	41
3-13	1.1		80	78	74	70	65	60	51	44
3-15	1.1		92	89	85	80	73	68	58	49
3-17	1.5		107	104	100	94	87	78	70	59
3-19	1.5		119	116	111	104	97	87	77	65
3-21	2.2		133	129	124	117	109	97	88	75
3-23	2.2		146	141	135	128	119	105	95	81
3-25	2.2		158	153	146	138	128	115	102	87
3-27	2.2		170	164	157	148	138	124	110	93
3-29	2.2		182	176	168	159	147	133	118	100
3-31	3.0		197	191	183	173	161	142	128	110
3-33	3.0		210	203	194	194	170	152	137	116
3-36	3.0		228	221	211	200	185	165	149	126

Hydraulic Performance Curves

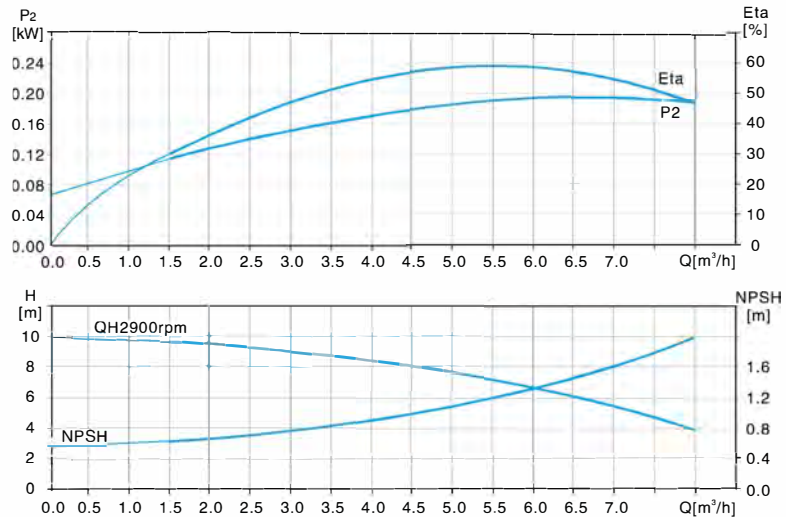
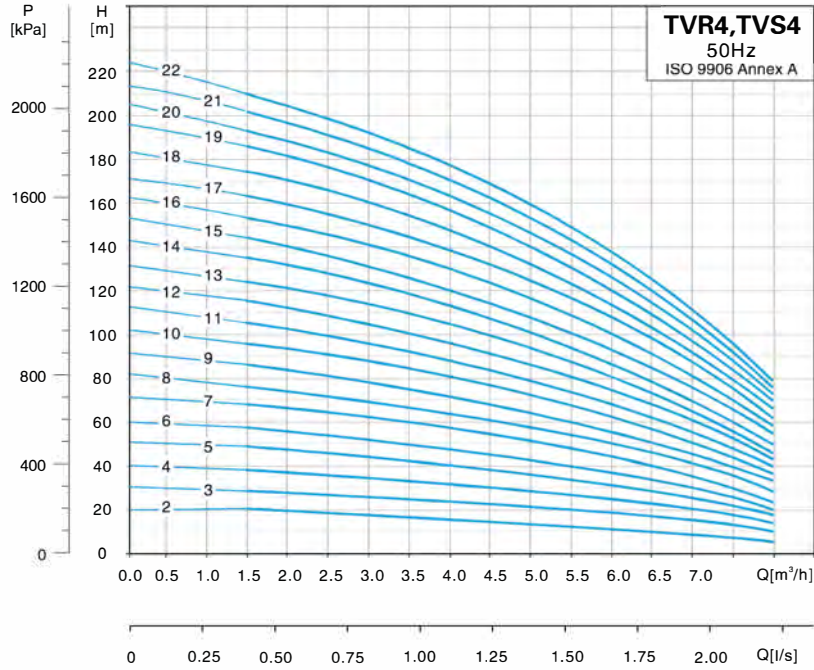

Dimension Drawing

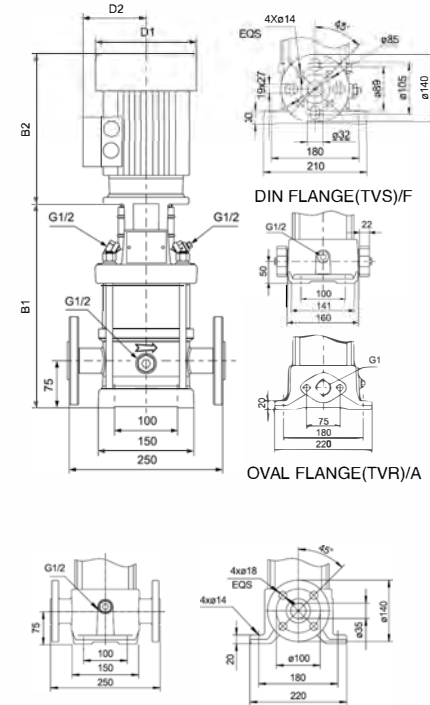

MODEL	OVAL FLANGE(TVR)		DIN FLANGE(TVS)		D1	D2
	B1	B1+B2	B1	B1+B2		
4-2	238	458	263	483	140	110
4-3	265	485	290	510	140	110
4-4	297	547	322	572	160	125
4-5	324	574	349	599	160	125
4-6	351	601	376	626	160	125
4-7	395	685	420	710	180	125
4-8	422	712	447	737	180	125
4-9	449	739	474	764	180	125
4-10	476	766	501	791	180	125
4-11	503	793	528	818	180	125
4-12	530	820	555	845	180	125
4-13	565	895	590	920	190	140
4-14	592	922	617	947	190	140
4-15	619	949	644	974	190	140
4-16	646	976	671	1001	190	140
4-17	673	1003	698	1028	220	150
4-18	700	1030	725	1055	220	150
4-19	727	1057	752	1082	220	150
4-20	754	1084	779	1109	220	150
4-21	781	1111	806	1136	220	150
4-22	808	1138	833	1163	220	150

Note: B1 and B1+B2 of clamp connector and threaded connector are in compliance with that of DIN flange.

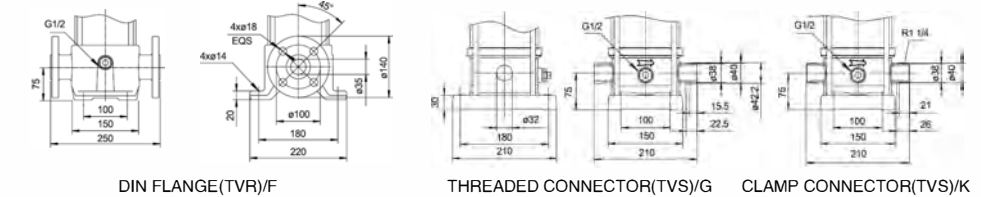

MODEL	POWER[kW]	Q[m³/h]	H(m)											
			1.5	2.0	3.0	4.0	5.0	6.0	7.0	8.0				
4-2	0.37	19	18	17	14.5	13	10.5	8	6					
4-3	0.55	28	27	26	23.5	20	18	14	10					
4-4	0.75	38	36	34	31.5	27	24.5	18	13					
4-5	1.1	47	45	43	40.5	34	31.5	23	17					
4-6	1.1	56	54	52	47.5	41	36	28	20					
4-7	1.5	66	63	61	57	48	44.5	34	24					
4-8	1.5	74	72	70	64	55	49.5	38	27					
4-9	2.2	86	81	78	72	63	56	44	32					
4-10	2.2	96	90	87	81	71	64	50	34					
4-11	2.2	105	99	95	88	78	69	53	39					
4-12	2.2	114	108	104	96	85	75	57	41					
4-13	3.0	123	117	113	103	93	83	63	45					
4-14	3.0	136	126	122	114	101	90	69	48					
4-15	3.0	142	135	131	120	108	96	73	52					
4-16	3.0	152	144	140	129	115	102	78	55					
4-17	4.0	163	153	149	137	122	108	83	62					
4-18	4.0	175	162	158	145	129	115	89	65					
4-19	4.0	183	171	168	155	137	123	95	67					
4-20	4.0	192	180	176	161	144	128	99	72					
4-21	4.0	203	210	184	169	152	134	103	75					
4-22	4.0	211	200	192	177	160	139	108	79					

Hydraulic Performance Curves

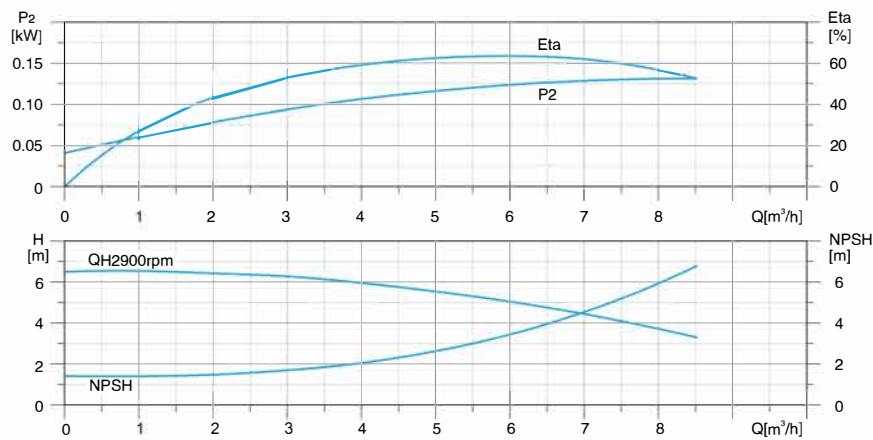
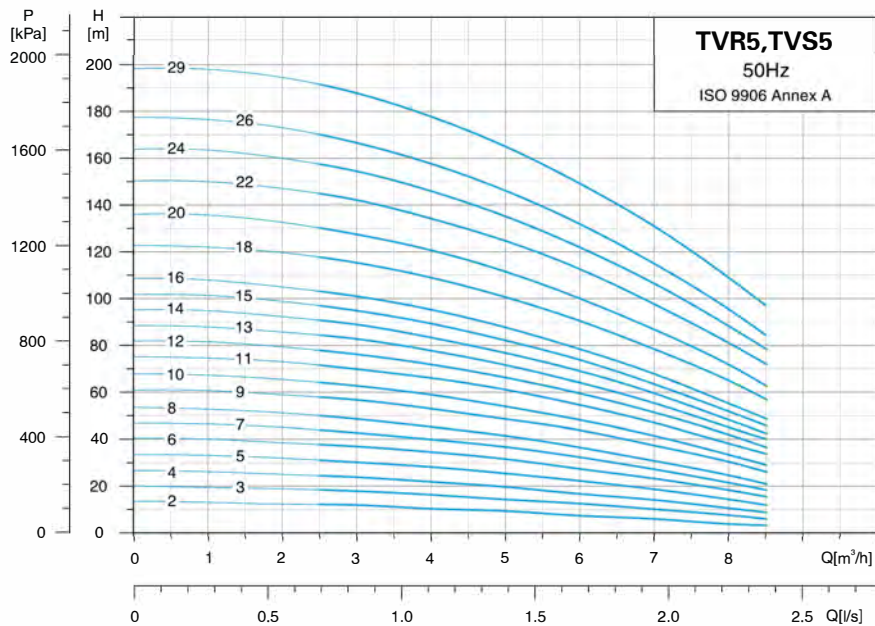

Dimension Drawing

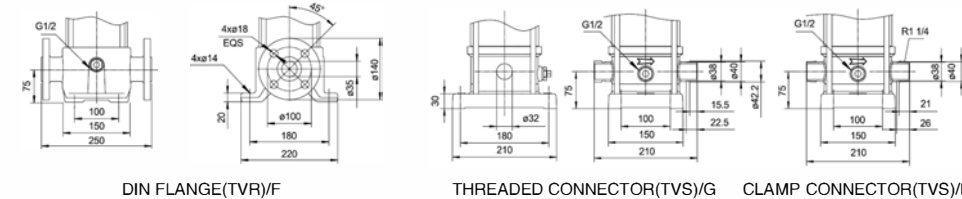
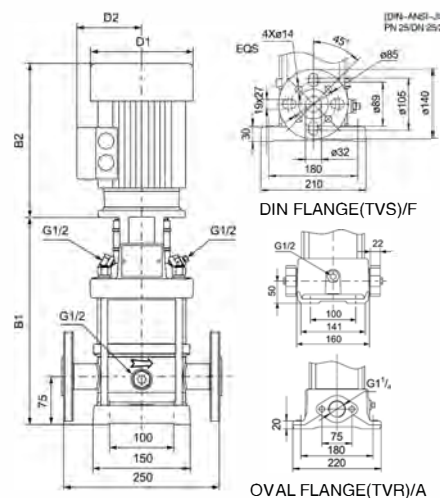

MODEL	OVAL FLANGE(TVR)		DIN FLANGE(TVS)		D1	D2
	B1	B1+B2	B1	B1+B2		
5-2	256	486	282	512	136	109
5-3	283	513	309	539	136	109
5-4	310	540	336	566	136	109
5-5	341	591	367	617	155	124
5-6	368	618	394	644	155	124
5-7	395	645	421	671	155	124
5-8	422	672	448	698	155	124
5-9	465	775	491	801	175	137
5-10	492	802	518	828	175	137
5-11	519	829	545	855	175	137
5-12	546	856	572	882	175	137
5-13	573	883	599	909	175	137
5-14	600	910	626	936	175	137
5-15	627	937	653	963	175	137
5-16	654	964	680	990	175	137
5-18	712	1042	738	1068	195	151
5-20	766	1096	792	1122	195	151
5-22	820	1177	846	1203	219	169
5-24	874	1231	900	1257	219	169
5-26	928	1285	954	1311	219	169
5-29	1009	1366	1035	1392	219	169

Note: B1 and B1+B2 of clamp connector and threaded connector are in compliance with that of DIN flange.

MODEL	POWER[kW]	Q[m³/h]	1.0	2.0	3.0	4.0	5.0	6.0	7.0
5-2	0.37		13	12	12	10	9	7	6
5-3	0.55		19	19	18	16	15	12	10
5-4	0.55		26	25	24	22	19	16	14
5-5	0.75		33	32	30	28	24	22	18
5-6	1.1		40	38	37	34	28	27	23
5-7	1.1		46	45	42	40	32	32	27
5-8	1.1		53	51	48	45	40	36	31
5-9	1.5		60	59	56	53	47	44	37
5-10	1.5		67	65	62	59	53	48	41
5-11	2.2		74	73	70	66	59	54	47
5-12	2.2		81	79	76	72	63	59	51
5-13	2.2		88	85	82	78	68	64	55
5-14	2.2		95	92	89	83	74	69	60
5-15	2.2		101	99	95	89	79	74	63
5-16	2.2		108	105	101	95	85	78	68
5-18	3.0		122	119	115	109	98	90	78
5-20	3.0		135	132	127	120	108	100	87
5-22	4.0		150	147	142	134	120	112	97
5-24	4.0		163	160	154	146	132	122	106
5-26	4.0		176	173	166	157	145	132	115
5-29	4.0		198	194	188	178	155	149	131

Hydraulic Performance Curves

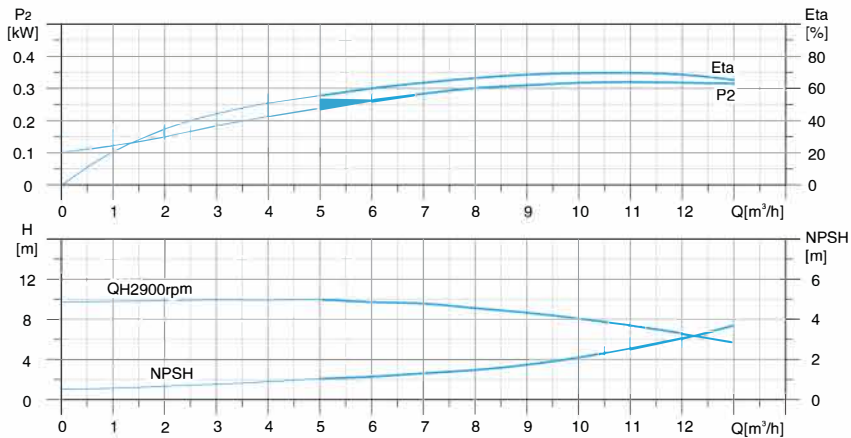
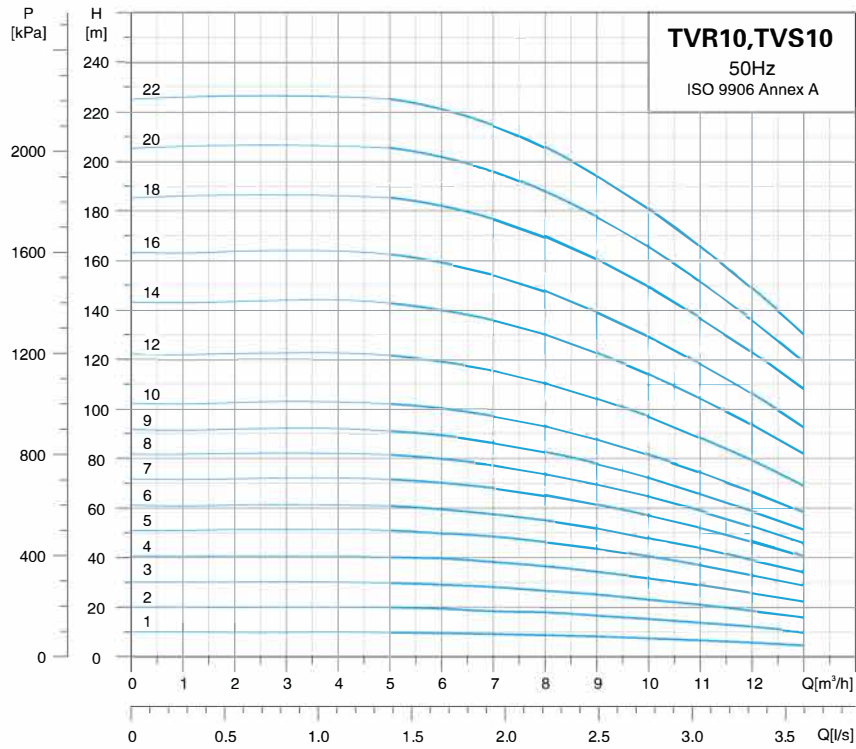

Dimension Drawing

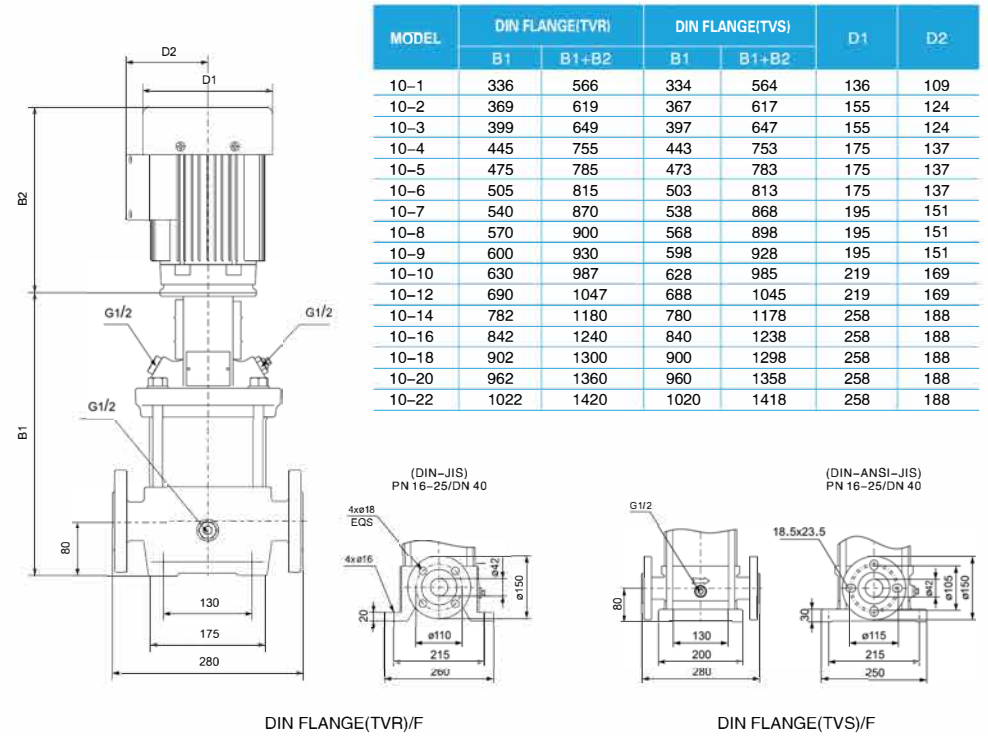

MODEL	DIN FLANGE(TVR)		DIN FLANGE(TVS)		D1	D2
	B1	B1+B2	B1	B1+B2		
10-1	336	566	334	564	136	109
10-2	369	619	367	617	155	124
10-3	399	649	397	647	155	124
10-4	445	755	443	753	175	137
10-5	475	785	473	783	175	137
10-6	505	815	503	813	175	137
10-7	540	870	538	868	195	151
10-8	570	900	568	898	195	151
10-9	600	930	598	928	195	151
10-10	630	987	628	985	219	169
10-12	690	1047	688	1045	219	169
10-14	782	1180	780	1178	258	188
10-16	842	1240	840	1238	258	188
10-18	902	1300	900	1298	258	188
10-20	962	1360	960	1358	258	188
10-22	1022	1420	1020	1418	258	188

MODEL	POWER[kW]	Q[m³/h]	2	4	6	8	10	12
10-1	0.37	10	10	10	9	8	7.5	5
10-2	0.75	20	20	20	19	18	15	12
10-3	1.1	30	30	30	29	26	23	18
10-4	1.5	40	40	40	40	36	32	26
10-5	2.2	51	51	51	50	46	40	33
10-6	2.2	61	61	61	59	55	48	39
10-7	3.0	72	72	70	65	56	46	39
10-8	3.0	82	82	80	74	64	53	46
10-9	3.0	92	92	89	82	70	59	46
10-10	4.0	102	102	100	93	80	66	53
10-12	4.0	122	122	119	110	95	79	66
10-14	5.5	143	144	140	130	113	94	79
10-16	5.5	163	163	159	148	128	106	86
10-18	7.5	185	186	182	169	147	123	106
10-20	7.5	206	204	201	188	164	136	113
10-22	7.5	226	226	221	206	178	147	123

Hydraulic Performance Curves

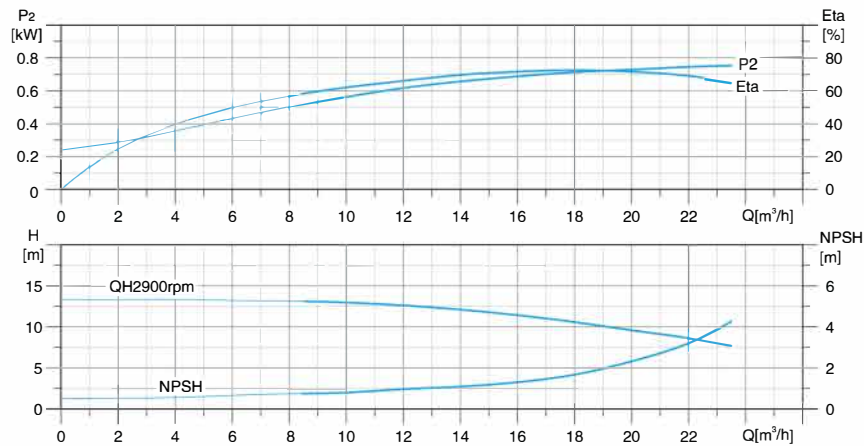
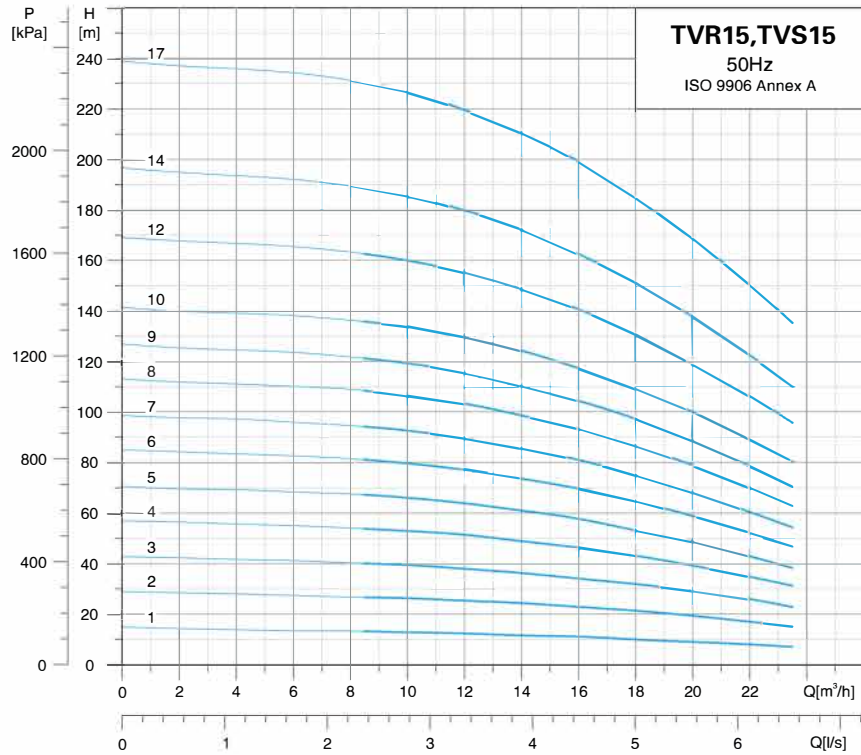

Dimension Drawing

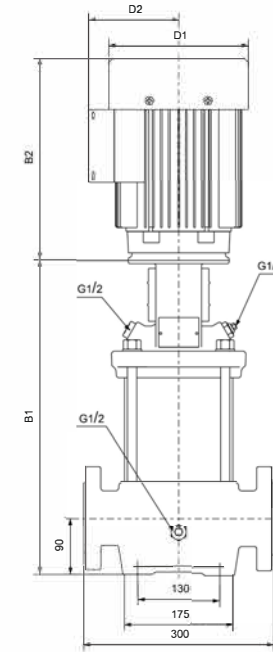

MODEL	DIN FLANGE(TVR)		DIN FLANGE(TVS)		D1	D2
	B1	B1+B2	B1	B1+B2		
15-1	354	604	352	602	155	124
15-2	415	725	413	723	175	137
15-3	465	795	463	793	195	151
15-4	510	867	508	865	219	169
15-5	555	912	553	910	219	169
15-6	632	1030	630	1028	258	188
15-7	677	1075	675	1073	258	188
15-8	722	1120	720	1118	258	188
15-9	767	1165	765	1163	258	188
15-10	889	1388	887	1386	315	242
15-12	979	1478	977	1476	315	242
15-14	1071	1570	1067	1566	315	242
15-17	1204	1703	1202	1701	315	242

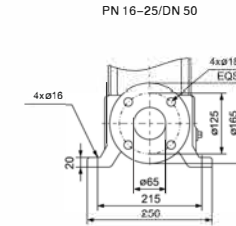

DIN FLANGE(TVR)/F

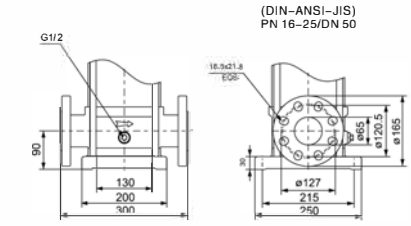

DIN FLANGE(TVS)/F

MODEL	POWER[kW]	Q[m³/h]	3	6	9	12	15	18	21
15-1	1.1	H(m)	15	13	13	12	11	10	9
15-2	2.2		28	27	26	25	23	21	18
15-3	3.0		42	41	40	38	35	32	28
15-4	4.0		58	55	55	51	47	43	38
15-5	4.0		70	68	66	64	58	53	48
15-6	5.5		83	82	80	77	71	64	58
15-7	5.5		98	96	94	89	83	75	65
15-8	7.5		112	110	108	103	96	86	75
15-9	7.5		125	123	120	115	108	97	84
15-10	11.0		140	138	136	129	120	109	95
15-12	11.0		168	165	162	155	142	130	114
15-14	11.0		194	192	188	180	166	151	130
15-17	15.0		237	234	230	219	205	185	160

Hydraulic Performance Curves

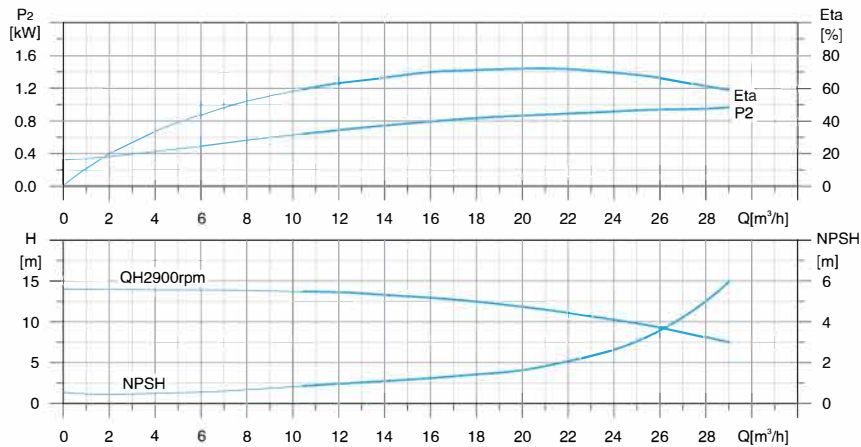
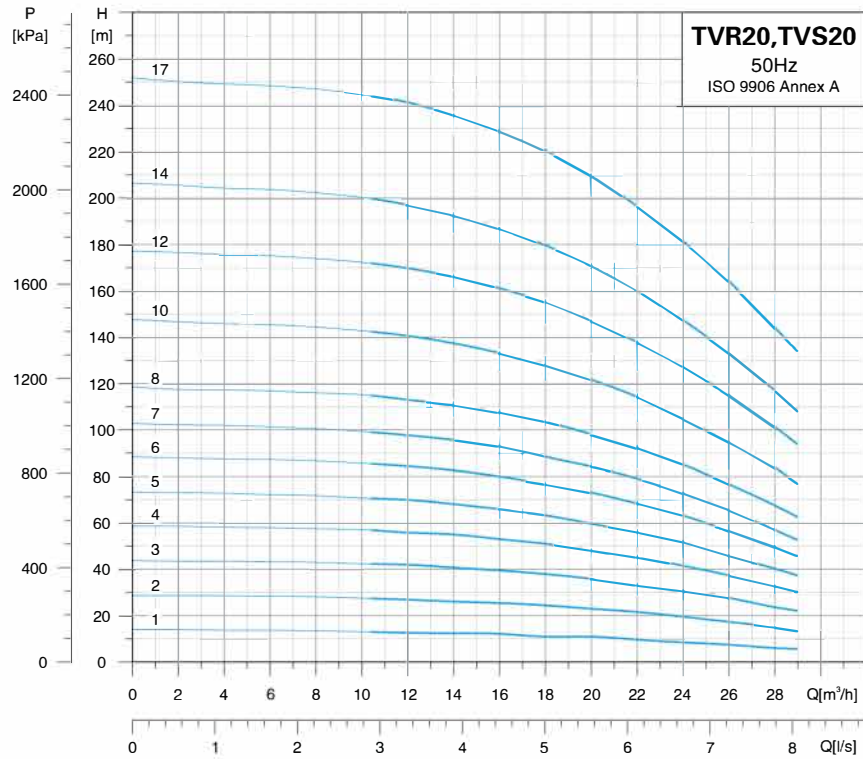

Dimension Drawing

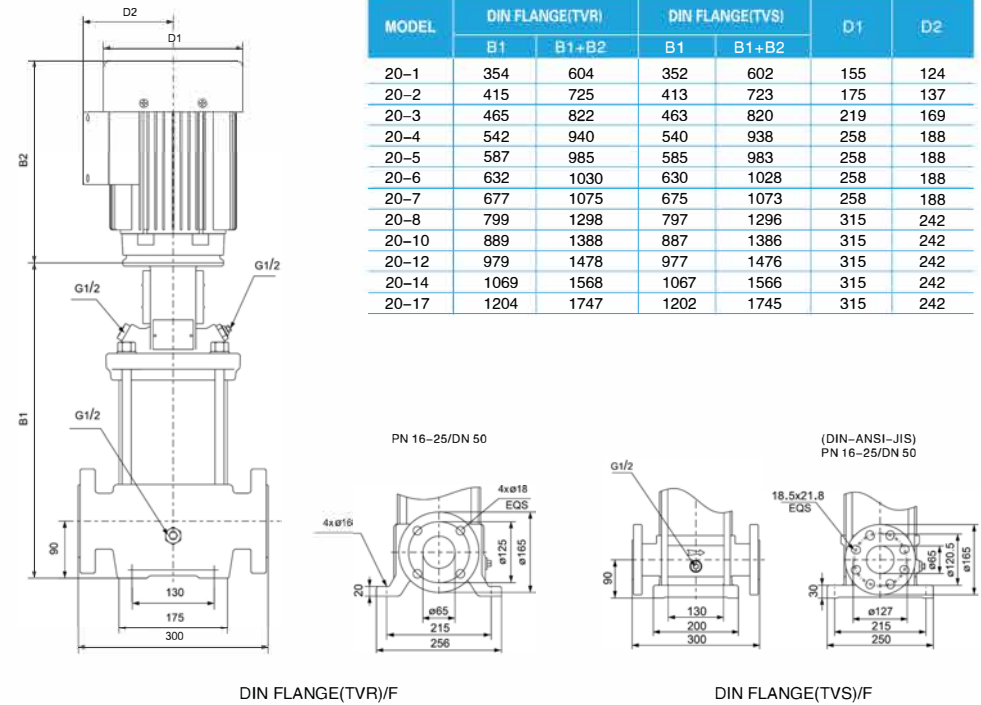

MODEL	POWER[kW]	Q[m³/h]	4	8	12	16	20	24	28
20-1	1.1	H(m)	13	13	13	12	10.5	9.5	6.5
20-2	2.2		28	28	27	25	22.5	19	15
20-3	4.0		43	43	42	39	36	30	23
20-4	5.5		58	57	56	53	48	41	32
20-5	5.5		73	72	70	66	60	52	40
20-6	7.5		87	83	84	80	72	62	49
20-7	7.5		102	100	97	93	84	72	57
20-8	11.0		117	116	113	107	96	85	67
20-10	11.0		146	144	140	132	120	105	83
20-12	15.0		175	174	169	161	144	127	101
20-14	15.0		204	202	197	187	168	147	117
20-17	18.5		249	247	241	229	205	181	144

Hydraulic Performance Curves

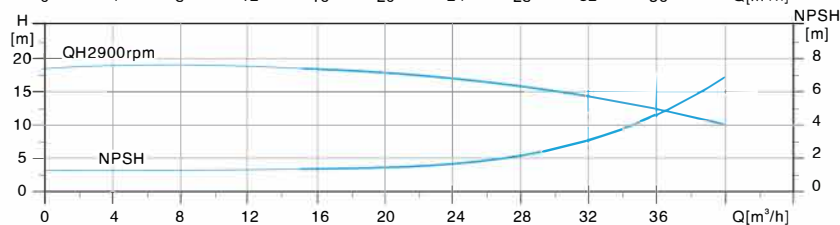
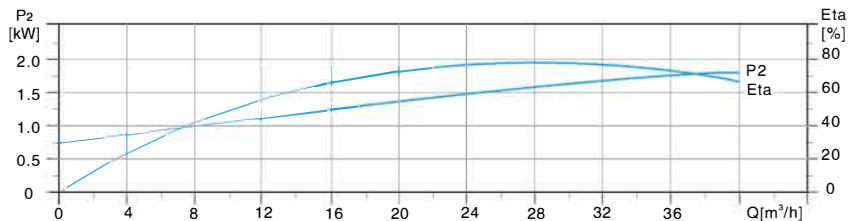
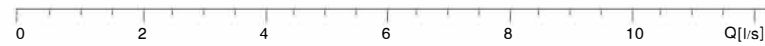
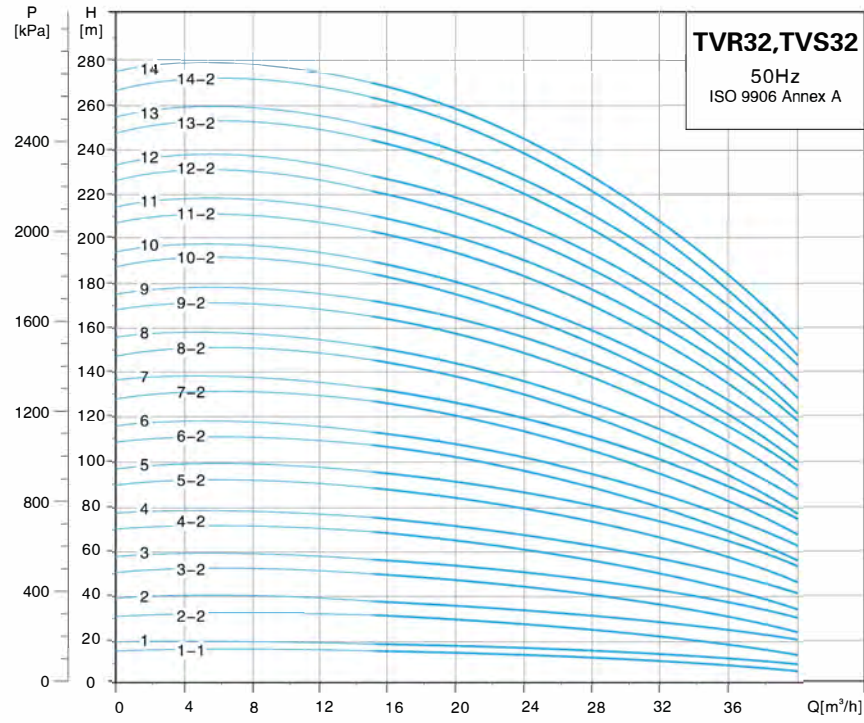

Dimension Drawing

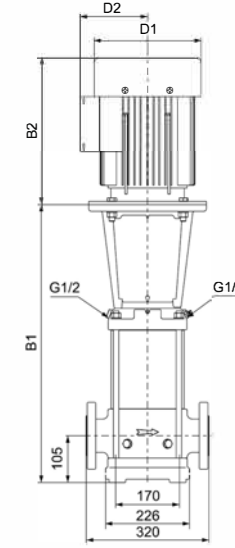

DIN FLANGE(TVS)/F

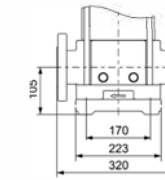

DIN FLANGE(TVR)/F

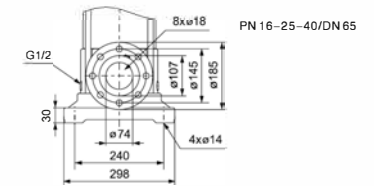

MODEL	DIN FLANGE(TVR,TVS)		D1	D2
	B1	B1-B2		
32-1-1	505	786	178	110
32-1	505	826	178	110
32-2-2	575	910	198	120
32-2	575	947	220	134
32-3-2	645	1036	220	134
32-3	645	1036	220	134
32-4-2	715	1106	220	134
32-4	715	1106	220	134
32-5-2	895	1393	334	263
32-5	895	1393	334	263
32-6-2	965	1463	334	263
32-6	965	1463	334	263
32-7-2	1035	1533	334	263
32-7	1035	1533	334	263
32-8-2	1105	1603	334	263
32-8	1105	1603	334	263
32-9-2	1175	1673	334	263
32-9	1175	1673	334	263
32-10-2	1245	1743	334	263
32-10	1245	1743	334	263
32-11-2	1315	1813	382	305
32-11	1315	1877	382	305
32-12-2	1385	1947	382	305
32-12	1385	1947	382	305
32-13-2	1455	2115	420	372
32-13	1455	2115	420	372
32-14-2	1525	2185	420	372
32-14	1525	2185	420	372

MODEL	POWER[kW]	Q[m³/h]	15	20	25	32	35	40
32-1-1	1.5		15	14	13	10	8	5
32-1	2.2		18	17	16	13	11.5	9
32-2-2	3		31	29.5	26.5	20.5	17.5	12
32-2	4		37	35.5	32.5	27.5	25	19.5
32-3-2	5.5		50	47	43.5	35.5	31	22.5
32-3	5.5		55.5	53	49	41.5	37.5	29.5
32-4-2	7.5		68.5	65	60	49.5	44	32.5
32-4	7.5		74.5	70.5	66	56	50.5	40
32-5-2	11		88.5	84.5	78	65.5	58.5	45
32-5	11		94.5	90	84	72	65	52
32-6-2	11		107	102	94.5	79.5	71	55
32-6	11		113	108	100	85.5	77.5	61.5
32-7-2	15		127	121	112	94.5	85	66.5
32-7	15		133	126	118	101	92	73.5
32-8-2	15		145	138	128	108	98	76.5
32-8	15		151	144	134	115	104	83
32-9-2	18.5		165	158	147	124	112	88.5
32-9	18.5		171	163	152	131	119	95.5
32-10-2	18.5		184	175	163	138	125	98.5
32-10	18.5		190	181	169	145	133	106
32-11-2	22		203	194	181	154	140	111
32-11	22		209	200	187	161	147	118
32-12-2	22		222	212	197	168	152	121
32-12	22		227	217	203	176	160	128
32-13-2	30		244	233	218	187	169	136
32-13	30		250	239	224	193	177	145
32-14-2	30		263	251	234	201	183	146
32-14	30		269	258	241	207	188	156

Hydraulic Performance Curves

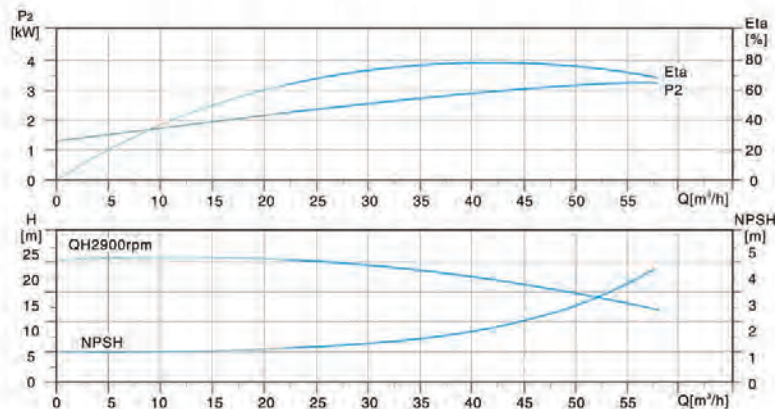
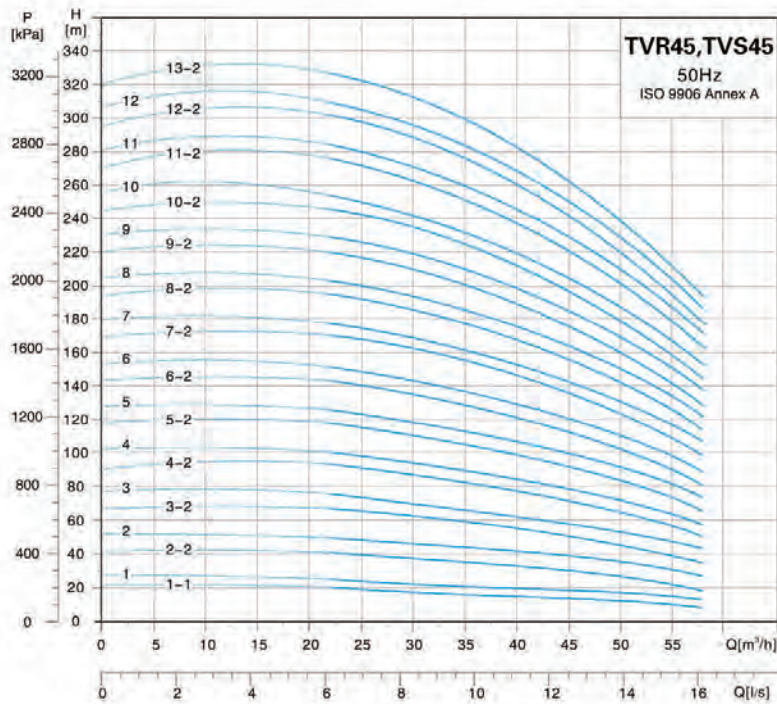

Dimension Drawing

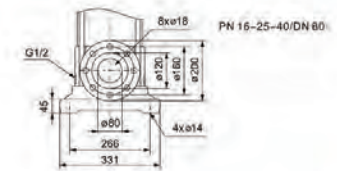
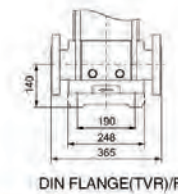
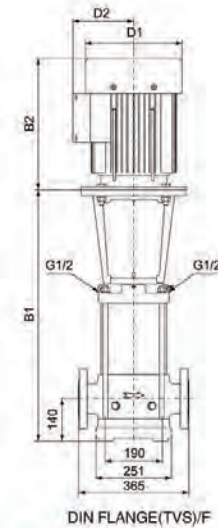

MODEL	DIN FLANGE(TVR, TVS)		D1	D2
	B1	B1+B2		
45-1-1	559	894	198	120
45-1	559	931	220	134
45-2-2	639	1030	220	134
45-2	639	1030	220	134
45-3-2	829	1327	334	263
45-3	829	1327	334	263
45-4-2	909	1407	334	263
45-4	909	1407	334	263
45-5-2	989	1487	334	263
45-5	989	1487	334	263
45-6-2	1069	1631	382	305
45-6	1069	1631	382	305
45-7-2	1149	1809	420	372
45-7	1149	1809	420	372
45-8-2	1229	1889	420	372
45-8	1229	1889	420	372
45-9-2	1309	1969	420	372
45-9	1309	1969	420	372
45-10-2	1389	2049	420	372
45-10	1389	2049	420	372
45-11-2	1469	2145	458	427
45-11	1469	2145	458	427
45-12-2	1549	2225	458	427
45-12	1549	2225	458	427
45-13-2	1629	2305	458	427

MODEL	POWER[kW]	Q[m³/h]	25	30	35	40	45	50	55
45-1-1	3		20	19.5	18	17	15	12.5	10.5
45-1	4		24	23	22	20.5	19	17.5	15
45-2-2	5.5		41	39	37	34	30.5	26.5	22
45-2	7.5		48.5	46.5	44.5	42	39	35	31
45-3-2	11		66	64	61	56.5	52	46	40
45-3	11		73.5	71	68	64	59.5	54	47.5
45-4-2	15		91	88	84	78.5	72	64.5	58
45-4	15		98.5	95	91	85.5	79.5	72.5	64
45-5-2	18.5		116	113	107	101	92.5	83.5	73
45-5	18.5		124	120	115	108	100	91.5	81
45-6-2	22		142	137	131	122	113	103	90
45-6	22		149	144	138	130	121	111	98
45-7-2	30		168	163	156	147	135	123	109
45-7	30		176	171	163	155	144	132	116
45-8-2	30		193	187	179	168	155	142	126
45-8	30		200	194	187	176	164	149	134
45-9-2	30		217	211	202	189	175	159	142
45-9	37		226	219	210	199	185	170	151
45-10-2	37		243	236	225	212	196	179	159
45-10	37		251	243	233	220	205	187	166
45-11-2	45		273	264	253	238	222	201	179
45-11	45		281	272	261	246	230	209	187
45-12-2	45		298	289	276	261	242	220	195
45-12	45		306	296	284	268	251	229	204
45-13-2	45		323	313	300	283	263	239	212

Hydraulic Performance Curves

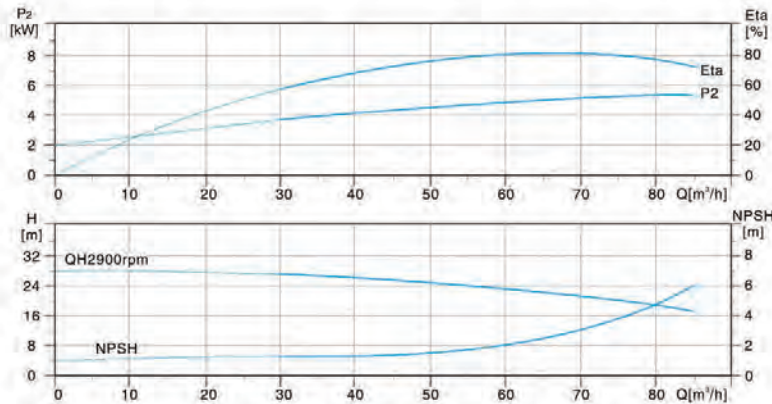
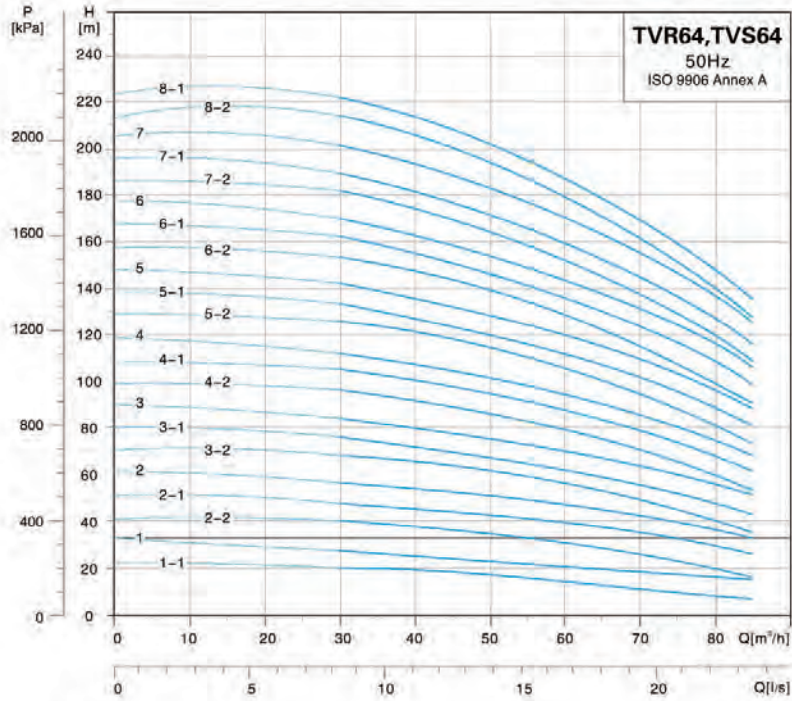

Dimension Drawing

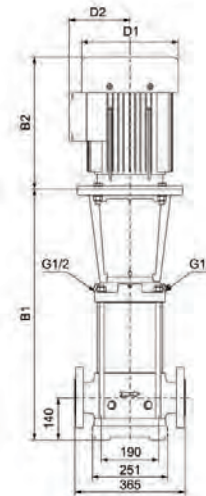

DIN FLANGE(TVS)/F

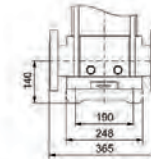

DIN FLANGE(TVR)/F

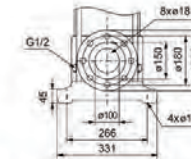

PN 16/DN 100

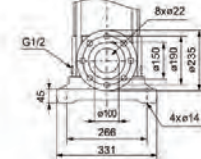

PN 25-40/DN 100

MODEL	DIN FLANGE(TVR,TVS)		D1	D2
	B1	B1+B2		
64-1-1	561	933	220	134
64-1	561	952	220	134
64-2-2	644	1035	220	134
64-2-1	754	1252	334	263
64-2	754	1252	334	263
64-3-2	836	1334	334	263
64-3-1	836	1334	334	263
64-3	836	1334	334	263
64-4-2	919	1417	334	263
64-4-1	919	1481	382	305
64-4	919	1481	382	305
64-5-2	1001	1661	420	372
64-5-1	1001	1661	420	372
64-5	1001	1661	420	372
64-6-2	1084	1744	420	372
64-6-1	1084	1744	420	372
64-6	1084	1744	420	372
64-7-2	1166	1826	420	372
64-7-1	1166	1826	420	372
64-7	1166	1842	458	427
64-8-2	1249	1925	458	427
64-8-1	1249	1925	458	427

MODEL	POWER(kW)	Q(m³/h)	30	40	50	64	70	80
64-1-1	4		20	19	17.5	15.5	12	8.5
64-1	5.5		27	25.5	23.5	21.5	20	17
64-2-2	7.5		40	38	35.5	31	25.5	19
64-2-1	11		48	45.5	42.5	38	34.5	29
64-2	11		55	52.5	49.5	44.5	41.5	36
64-3-2	15		68	65.5	60	54	48.5	40
64-3-1	15		75.5	72	67.5	60	55.5	47
64-3	18.5		83.5	80	76	66.5	64	56
64-4-2	18.5		96	92.5	87	76	70	59
64-4-1	22		104	100	94.5	82.5	78.5	67.5
64-4	22		112	107	102	89	85.5	74.5
64-5-2	30		126	122	115	100	94	80.5
64-5-1	30		134	129	122	106	102	88
64-5	30		141	136	129	113	109	96
64-6-2	30		154	148	140	122	115	99
64-6-1	37		162	156	148	129	124	108
64-6	37		170	163	155	135	131	116
64-7-2	37		182	176	166	145	138	119
64-7-1	37		190	183	173	151	145	126
64-7	45		202	194	184	163	155	136
64-8-2	45		214	207	196	172	163	140
64-8-1	45		222	214	203	180	170	148

Hydraulic Performance Curves

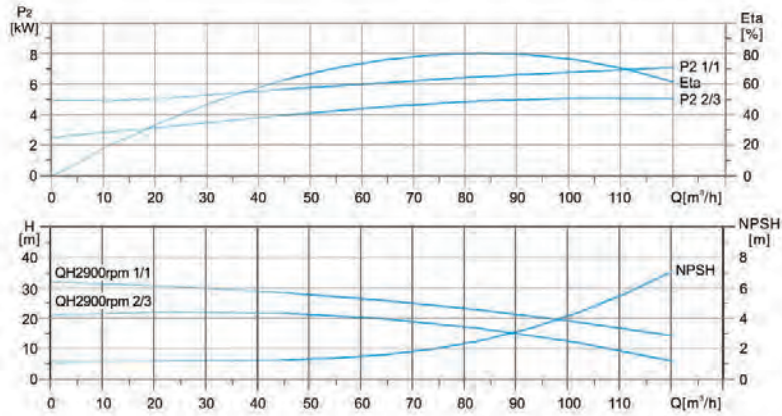
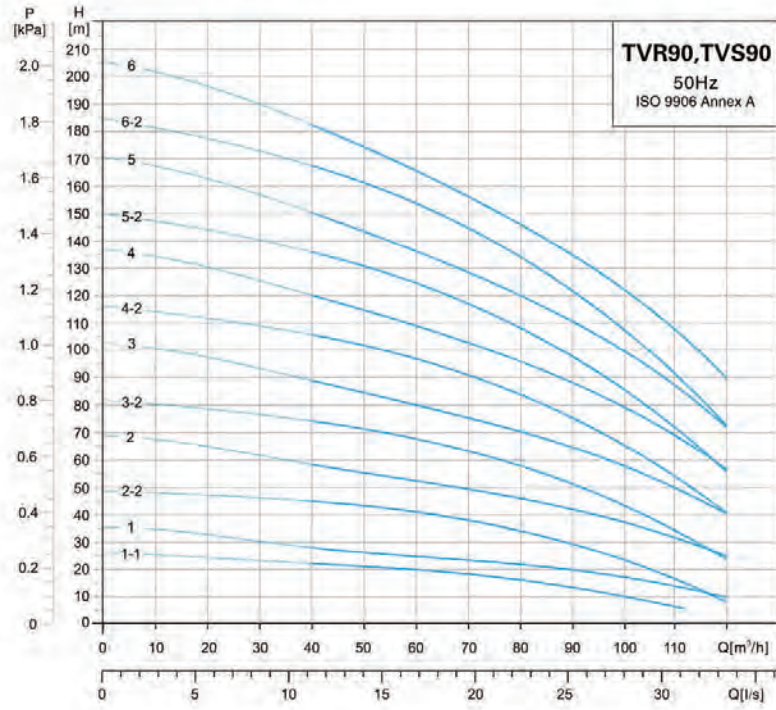

Dimension Drawing

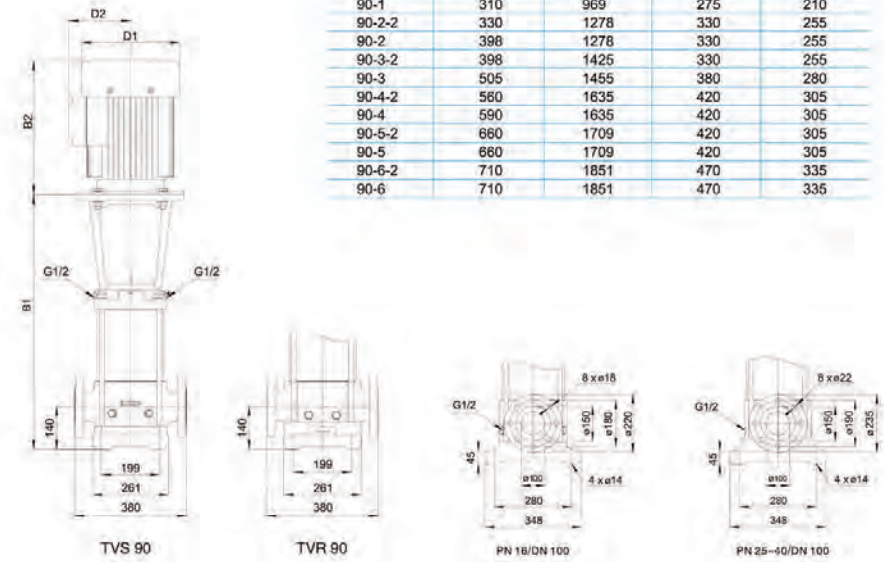

MODEL	DIN FLANGE(TVR,TVS)		D1	D2
	B1	B1+B2		
90-1-1	310	969	275	210
90-1	310	969	275	210
90-2-2	330	1278	330	255
90-2	398	1278	330	255
90-3-2	398	1425	330	255
90-3	505	1455	380	280
90-4-2	560	1635	420	305
90-4	590	1635	420	305
90-5-2	660	1709	420	305
90-5	660	1709	420	305
90-6-2	710	1851	470	335
90-6	710	1851	470	335

MODEL	POWER(kW)	Q[m³/h]	50	60	70	80	90	100	110
90-1-1	5.5	H(m)	21	20	18	16	14	10.5	6.5
90-1	7.5		26	25	23.5	22	20	17.5	14
90-2-2	11		43	41	38	34.5	30	24	17
90-2	15		55	52	49	46	42.5	37.5	31.5
90-3-2	18.5		71.5	68	63.5	58	51.5	44	35
90-3	22		84.5	80	75.5	70.5	65	58.5	50.5
90-4-2	30		102	97	91	84.5	76	65.5	54
90-4	30		114	109	103	96	88.5	79.5	69.5
90-5-2	37		131	125	118	109	98.5	86.5	72
90-5	37		144	136	129	121	111	101	87
90-6-2	45		161	154	145	135	123	108	91.5
90-6	45		175	166	156	146	135	123	108

Hydraulic Performance Curves

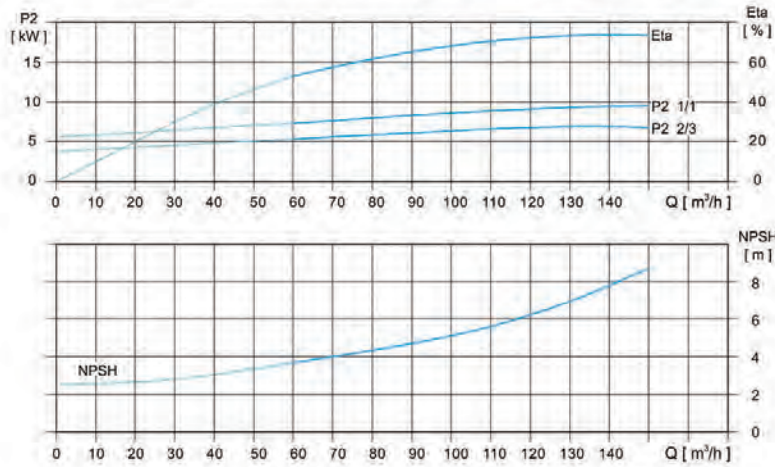
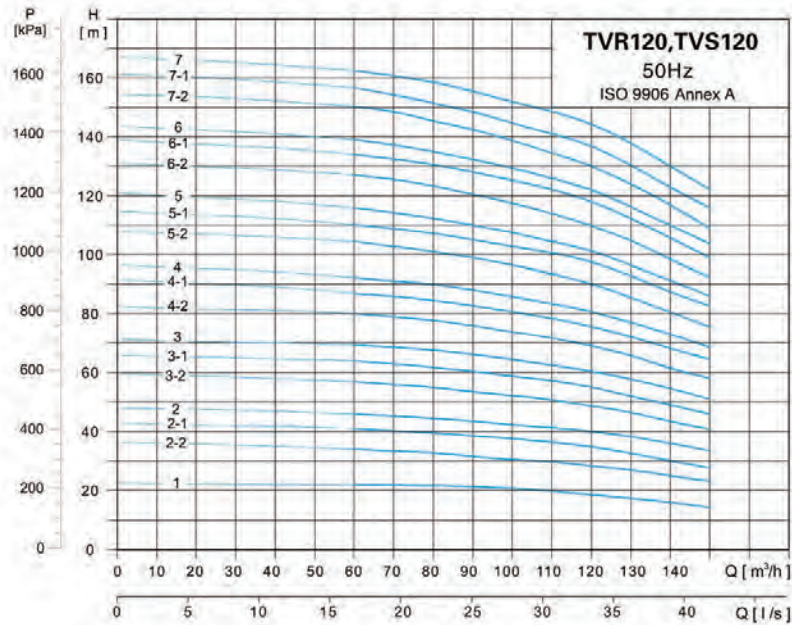

Dimension Drawing

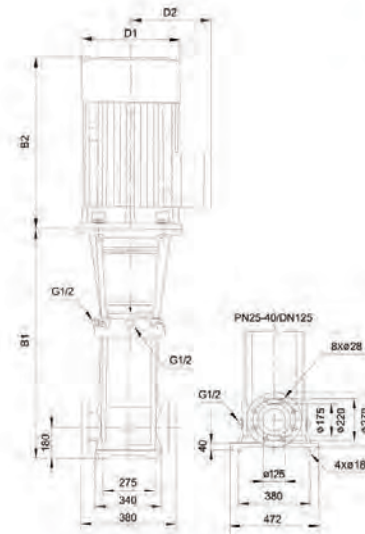

MODEL	DIN FLANGE (TVR, TVSI)		D1	D2
	B1	E1 + B2		
120-1	840	1333	254	175
120-2-2	1000	1493	254	175
120-2-1	1000	1580	330	250
120-2	1000	1600	380	280
120-3-2	1160	1840	420	305
120-3-1	1160	1840	420	305
120-3	1160	1840	420	305
120-4-2	1320	2000	420	305
120-4-1	1320	2000	420	305
120-4	1320	2035	470	335
120-5-2	1480	2195	470	335
120-5-1	1480	2195	470	335
120-5	1480	2295	510	370
120-6-2	1670	2455	510	370
120-6-1	1670	2455	510	370
120-6	1670	2515	580	410
120-7-2	1830	2675	580	410
120-7-1	1830	2675	580	410
120-7	1830	2675	580	410

MODEL	POWER (kW)	Q (m³/h)	H (m)												
			60	70	80	90	100	110	120	130	140	150			
120-1	11		22	21.8	21.6	21	20.5	19.5	18.5	17	16	15			
120-2-2	15		34	33.6	33	31	30.2	30	28.5	27	25	24			
120-2-1	18.5		41	40	39.5	38.5	37	36.5	34.5	32.5	30	27.5			
120-2	22		46	45	44.5	43.5	42.4	41	40	38	36	33.5			
120-3-2	30		57	56	55	53.5	52	51	49	46.5	43.5	41			
120-3-1	30		64	63	62	60	58.5	57.5	55.5	52	49	46			
120-3	30		69.5	68.5	67.5	66	64.4	62.5	61	57.5	54.5	51			
120-4-2	37		80.5	79	78	76	73.5	72	69	66	61.5	58			
120-4-1	37		87	86	84.5	82	80	78	76	72	68	64.5			
120-4	45		92.5	91	90	88	85.5	83	81	77	73	68.5			
120-5-2	45		104.5	103	101	99	96	93	90	85.5	80.5	75.5			
120-5-1	45		110.5	109	107.5	105	102	100	97	92	86.5	83			
120-5	55		115.5	114	113	110	107.5	104.5	101.5	96	91	86			
120-6-2	55		128	125.5	123	121	117.3	113.5	110	104.5	98.5	92.5			
120-6-1	55		134	132	130.5	127	124	121	118	111	105	100			
120-6	75		139	137	135	132	128.8	126	123	116	110	104			
120-7-2	75		151	148	145.5	143	138.6	134	130	123.5	116.5	109			
120-7-1	75		156.5	154	152	148.5	144.5	141	137.5	130	123	116.5			
120-7	75		162.5	160.5	158.5	155	151	148	145	137	129	123			

Hydraulic Performance Curves

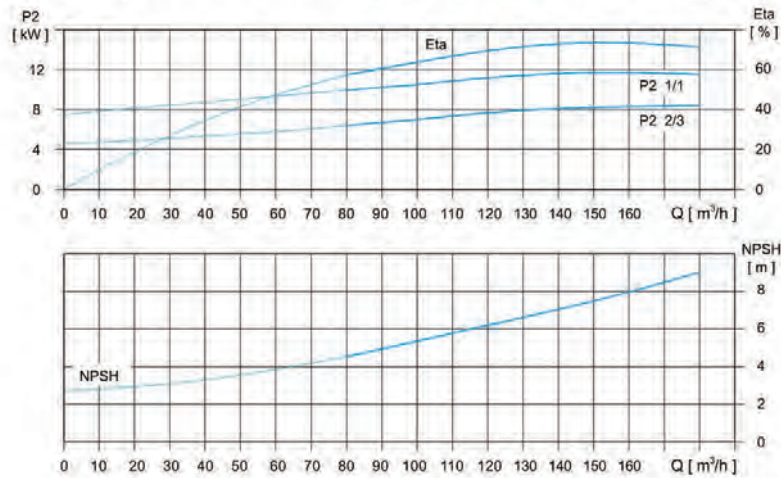
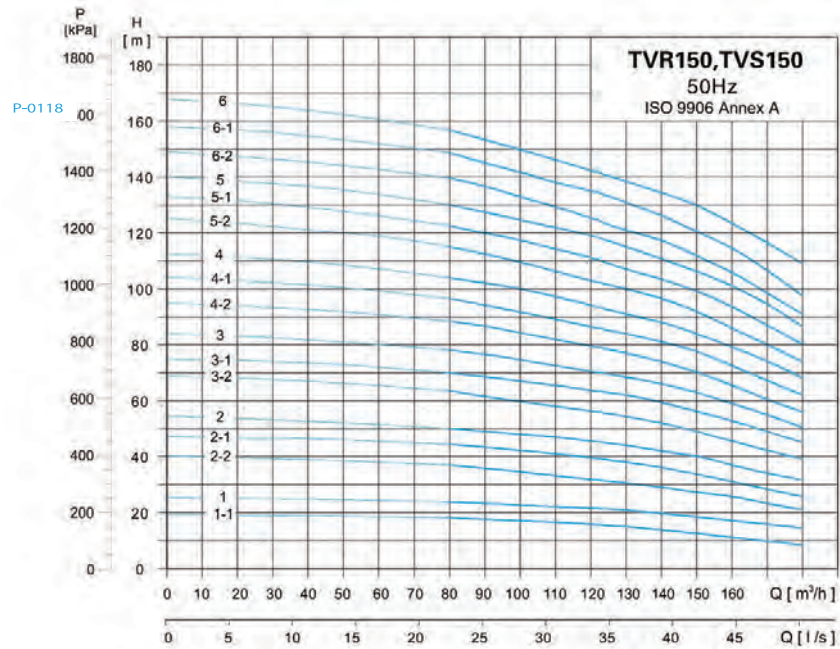

Dimension Drawing

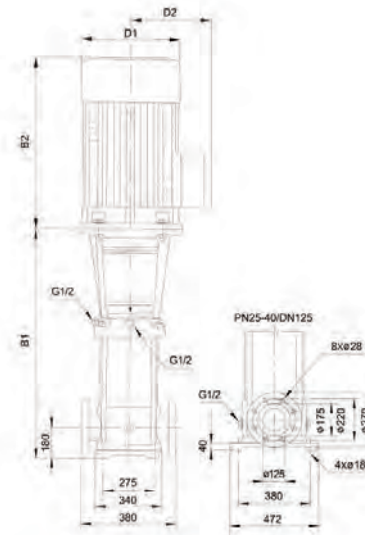

MODEL	DIN FLANGE(TVR,TVS)		D1	D2
	B1	B1+B2		
150-1-1	840	1333	254	175
150-1	840	1333	254	175
150-2-2	1000	1560	330	250
150-2-1	1000	1600	380	280
150-2	1000	1680	420	305
150-3-2	1180	1840	420	305
150-3-1	1160	1840	420	305
150-3	1160	1840	420	305
150-4-2	1320	2035	470	335
150-4-1	1320	2035	470	335
150-4	1350	2135	510	370
150-5-2	1510	2295	510	370
150-5-1	1510	2355	580	410
150-5	1510	2355	580	410
150-6-2	1670	2515	580	410
150-6-1	1670	2515	580	410
150-6	1670	2515	580	410

MODEL	POWER[kW]	Q[m³/h]	80	90	100	110	120	130	140	150	160	170	180
150-1-1	11		18.3	17.8	17.3	17	16	15	14	12.5	11	10	8.5
150-1	15		24	23	22.5	22	21.5	20.5	20	18.5	17	16	15
150-2-2	18.5		37	35.5	34	33	32	31	29	27.5	26	23	21
150-2-1	22		44.3	43	42	40	39	38.5	37.5	35	33	30	27
150-2	30		50	49	48	47	45.5	44	42	40	37	34	32
150-3-2	30		63.5	61	59	57.5	56	54.5	53	49	45.5	42	39
150-3-1	30		70	68	67	65	63	62	60	56	53	49	45
150-3	37		78	76.5	75	73	70.5	68	66	63	59	55	50.5
150-4-2	37		89	87	84	81.5	79	77	74.5	70.5	65.5	60	56
150-4-1	45		96.5	94	91.5	89	86.5	84	81.5	77	72.5	67	62
150-4	45		104	102	100	97	95	91	88	84	79.5	74	68
150-5-2	55		115.5	112	109	106	102.5	100	97	92	86	79	73.5
150-5-1	55		122.5	119.5	117	113.5	111.5	107.5	104.5	99	93.5	87	80
150-5	75		130	127.5	125	121	119	115	111.5	106.5	101	94.5	86.5
150-6-2	75		140	137	133	130	126	121	118	112	106	98	91
150-6-1	75		148.5	145	141.7	137.5	135	131	127	120.5	114.5	106.5	97.5
150-6	75		157	153	149	145	142	139.5	137	130	123.5	116	109

Hydraulic Performance Curves

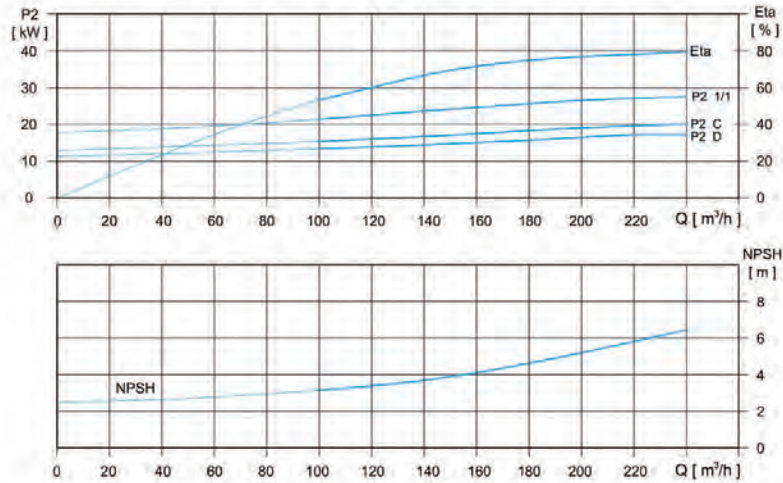
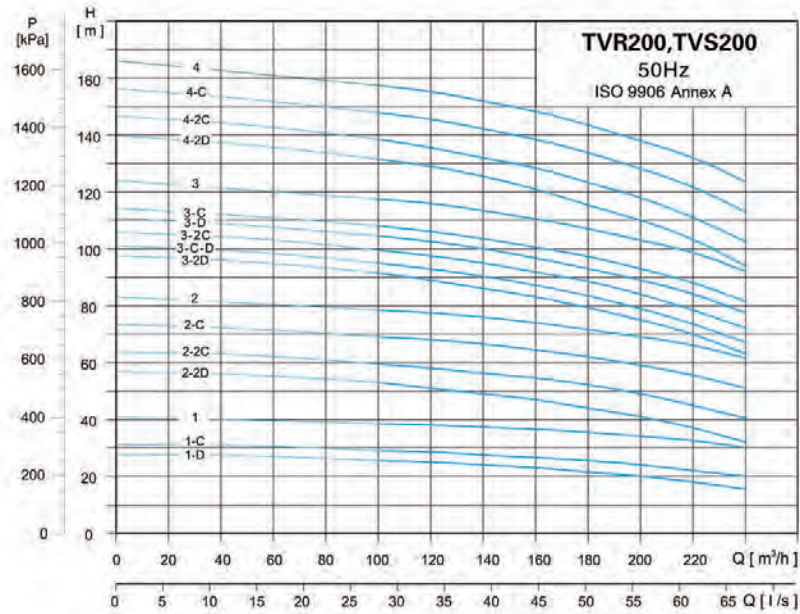

Dimension Drawing

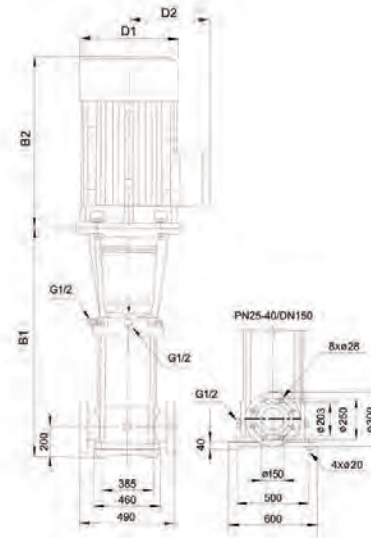

MODEL	DIN FLANGE(TVR,TVSI)		D1	D2
	B1	B1+B2		
200-1-D	907	1467	330	250
200-1-C	907	1507	380	280
200-1	907	1587	420	305
200-2-2D	1101	1781	420	305
200-2-2C	1101	1816	470	335
200-2-C	1131	1916	510	370
200-2	1131	1916	510	370
200-3-2D	1325	2170	580	410
200-3-C-D	1325	2170	580	410
200-3-2C	1325	2170	580	410
200-3-D	1325	2170	580	410
200-3-C	1325	2170	580	410
200-3	1325	2220	580	410
200-4-2D	1519	2414	580	410
200-4-2C	1519	2619	645	530
200-4-C	1519	2619	645	530
200-4	1519	2619	645	530

MODEL	POWER(kW)	Q[m³/h]	H(m)																	
			100	120	140	160	180	200	220	240										
200-1-D	18.5		25.5	25	24	23	21.5	20	18	15.5										
200-1-C	22		29	28.5	27.5	26.5	25.5	24	22	20										
200-1	30		38.5	38	37.5	36.5	35	34	32.5	30										
200-2-2D	37		53	51	49	47	44	41	37	32										
200-2-2C	45		59.5	58	56	54	52.5	49	44.5	40.5										
200-2-C	55		69	68	66	64	62	59	55.5	51										
200-2	55		78.5	77.5	76	74	71.5	69	66	61.5										
200-3-2D	75		91.5	89	86.5	83.5	79	75	70	63										
200-3-C-D	75		95	93	90	87	83.5	79	73.5	67										
200-3-2C	75		99.5	97.5	94.5	91.5	89	84	78.5	72										
200-3-D	75		104.5	102.5	100	97	93	89	84.5	77.5										
200-3-C	75		108	106	103.5	100.5	97.5	93	88	81.5										
200-3	90		117.5	116	113.5	110.5	107	103	99	92										
200-4-2D	90		131.5	129	125.5	121	115.5	110	103.5	94										
200-4-2C	110		138.5	136	132	128	124	118	111	102.5										
200-4-C	110		148	145.5	142.5	138	134	128	122	113										
200-4	110		157.5	155.5	152.5	148	143.5	138	132.5	123.5										